

UNIT-2 SURVEYING & POSITIONING

SURVEYING & POSITIONING

1. Linear measurements: Chain and Tape Surveying, Errors, Obstacles, Booking and Plotting, Calculation of Areas.
2. Angular Measurements: Bearing, Prismatic Compass, Local Attraction, Bowditch's Rule of correction, traverse open and closed, plotting of traverse, accuracy and precision.
3. Levelling: Types of Levels, Levelling Staff, Measurements, recording, curvature and Refraction correction, reciprocal levelling, sensitivity of level.
4. Contours: Properties, uses, plotting of contours, measurement of drainage and volume of reservoir.
5. Measurement of area by Planimeter.

Surveying is the science of making measurements to determine the positions of points or stations, above, on or beneath the surface of the earth. The process of surveying is carried out in land, water and also in space. The measurements involved in surveying are mainly distances (both horizontal and vertical) and directions. The data procurement phase in surveying is called field work and the analysis of data is called as office computations.

Classification of surveys:

A. Classification based on the location of survey as:

- a. Land surveys.
- b. Hydrographic surveys.
- c. Astronomical surveys.

B. Classification based on the purpose of survey as:

- a. Topographical survey.
- b. Land survey.
- c. Engineering survey.
- d. Geodetic survey.

C. Classification based on the instruments or method employed as:

- a. Chain and tape survey.
- b. Compass and Theodolite survey.
- c. Plane table survey.
- d. Triangulation survey.
- e. Tacheometric survey.

- f. Hydrographical survey.
- g. Photographical and aerial survey.

Geodetic survey:

In this survey the area to be surveyed is considerably large to include the curvature of the earth. Geodetic surveying involves extremely accurate measurements of distances and angles. Adequate recognition is given to the spheroidal shape of the earth and in the computations provisions are made for convergency of the true meridians, and for correcting the lengths of base lines to the equivalent length projected on the mean sea level.

Plane surveying:

This branch of surveying considers the surface of the earth under survey to be plane. Curvature of earth is ignored and all calculations are made by using formulae of plane trigonometry. All meridians are taken as parallel. All plumb lines are taken as parallel. Plane surveying principles are followed for small areas.

Topographical survey:

This is a survey undertaken to establish on a map the topography or the natural features of the area, like rivers, canals, lakes, roads, railways, towns, etc.

Land surveys:

This is a survey done to fix property lines, calculation of land areas and transfer of real property from one owner to the other.

Engineering Surveys:

These consists of operations of obtaining data required to plan and design an engineering project and providing the proper position and dimensional control at the site so that the building or the project or the highway etc. is constructed in the proper place and as designed.

Basic principle of surveying:

The following two basic principles should be considered while determining relative position of points on the surface of earth:-

1. Determining suitable method for locating a point: - it is always practicable to select two points in the field to measure the distance between them. These can be represented on paper by two points placed in a convenient position.
2. Working from whole to the part: - in surveying an area, it is essential to establish first of all a system of control points with great precision. Minor control points can then be established by less precise method and the details

can be located afterwards by method of triangulation or traversing between control points.

Chain surveying

Chain surveying is a method of surveying in which only linear measurements are directly made in the field. The main instruments used are chain, tape, offset rods, cross staff, optical square. This is the simplest method of surveying which is resorted in the following cases:

1. For small areas.
2. To prepare large scale maps and to locate boundaries very accurately.
3. The site is an open ground without complicated undulating profiles, obstacles etc.
4. The ground is fairly level.

Principle of chain surveying:

The plot is divided into a number of well conditioned (nearly equilateral) triangles. This triangle is surveyed. The area within each primary triangle can be divided into minor or secondary triangles which are all surveyed for their exact location within each primary triangle. This process is based on working from whole to part and the accumulation of errors is avoided.

Instruments used in chain surveying:

The chain: A chain is a unit of length. It measures 66 feet, or 22 yards, or 100 links, or 4 rods (20.1168 m). In 1620, the clergyman Edmund Gunter developed a method of surveying land accurately with low technology equipment, using what became known as Gunter's chain; this was 66 feet long and from the practice of using his chain, the word transferred to the actual measured unit. His chain had 100 links, and the link is used as a subdivision of the chain as a unit of length. The chain also survives as the length of a cricket pitch, being the distance between the wickets. The chain is composed of one hundred links, connected each to each by two rings, and furnished with a tally mark at the end of every ten links. A link in measurement includes a ring at each end, and is seven and ninety two one hundredths inches long. In all the chains which we make the rings are oval and are sawed and well closed, the ends of the wore forming the hook being also filed and bent close to the link, to avoid kinking. The oval rings are about one third stronger than round ones.

Handles - The handles are of brass and form part of the end links, to which they are

connected by a short link and jam nuts, by which the length of the chain is adjusted. Tallies - The tallies are of brass, and have one, two, three or four notches, as they mark ten, twenty, thirty or forty links from either end. The fiftieth link is marked by a rounded tally to distinguish it from the others.

Following are the various types of chain in common use:

1. Metric chains
2. Gunter`s chain or surveyors chain
3. Engineers chain
4. Revenue chain

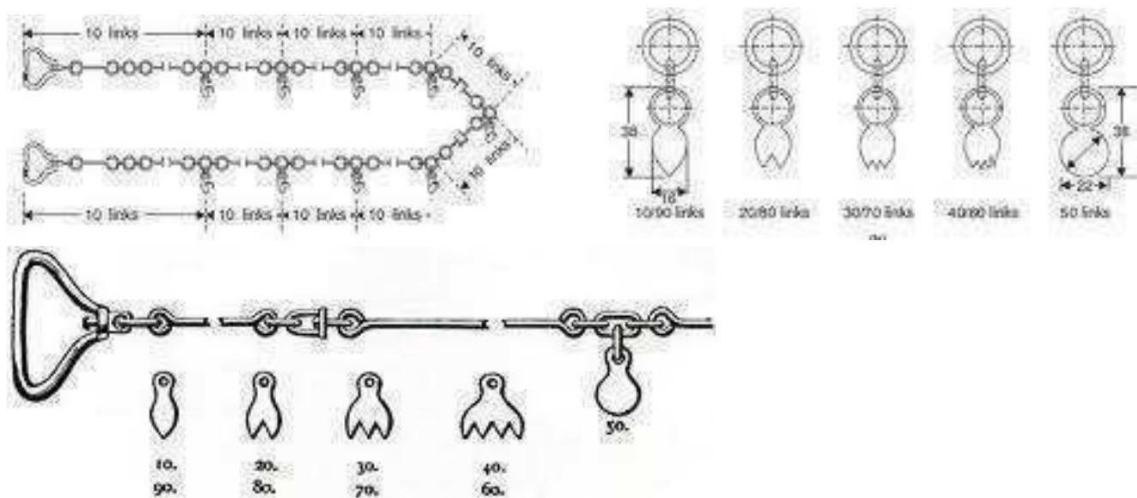

Figure 1: Chains

Metric chain: Metric chains are made in lengths 20 m and 30 m . Tallies are fixed at every five meter length and brass rings are provided at every meter length except where tallies are attached

Engineers' Chains - Engineers' chains differ from surveyors' chains, in that a link including a ring at each end is one foot long, and the wire is of steel Nos. 8, 10 and 12. They are either fifty or one hundred feet long, and are furnished with swivel handles and tallies like those just described.

Tapes

Tapes are used in surveying to measure horizontal, vertical, and slope distances. They may be made of a ribbon or a band of steel, an alloy of steel, cloth reinforced with metal or synthetic materials. Tapes are issued in various lengths and widths and graduated in a variety of ways. The following are the various types of tapes

- i. Cloth tape
- ii. Metallic tape
- iii. Steel tape
- iv. Invar tape

Among the above, metallic tapes are widely used in surveying. A metallic tape is made of varnished strip of waterproof line interwoven with small brass, copper or bronze wires. These are light in weight and flexible and are made 2 m, 5 m, 10 m, 20 m, 30 m, and 50 m .

Metallic Tapes: A metallic tape is made of high-grade synthetic material with strong metallic. Strands (bronze-brass- copper wire) woven in the warped face of the tape and coated with a tough plastic for durability. Standard lengths are 50 and 100 ft. Metallic tapes are generally used for rough measurements, such as cross-sectional work, road-work slope staking, side shots in topographic surveys, and many others in the same category. Nonmetallic tapes woven from synthetic yarn, such as nylon, and coated with plastic are available; some surveyors prefer to use tapes of this type. Nonmetallic tapes are of special value to power and utility field personnel, especially when they are working in the vicinity of high-voltage circuits.

Steel Tapes

For direct linear measurements of ordinary or more accurate precision, a steel tape is required. The most commonly used length is 100 ft , but tapes are also available in 50-, 200-, 300-, and 500-ft lengths.

Various types of surveying tapes are shown in figure 2. View A shows a metallic tape; view B, a steel tape on an open reel; view C , a steel tape or, a closed reel. View D shows a special type of low-expansion steel tape used in high-order work; it is generally called an Invar tape or Lovar tape.

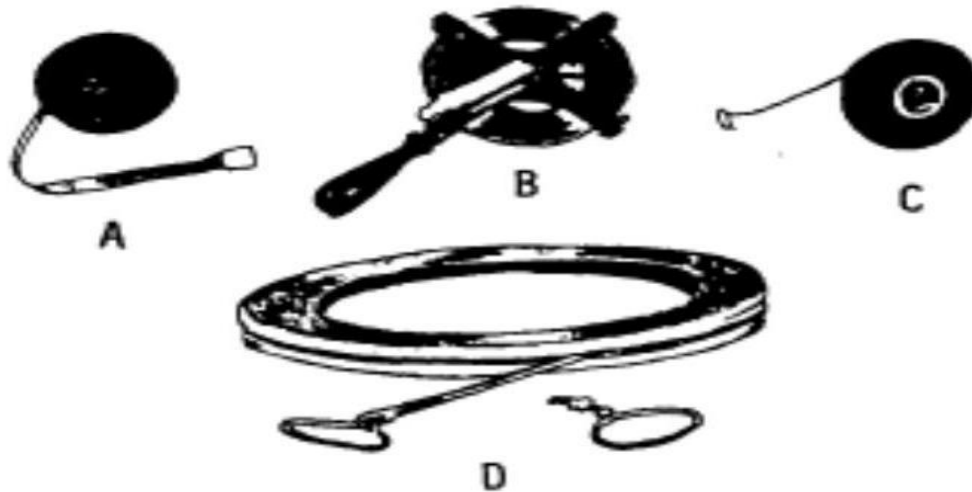

Figure 2: Surveying tapes.

Invar Tapes

Nickel-steel alloy tapes, known as Invar, Nilvar, or Lovar, have a coefficient of thermal expansion of about one-tenth to one-thirtieth (as low as 0.0000002 per 10 F) that of steel. These tapes are used primarily in high-precision taping. These tapes must be handled in exactly the same manner as other precise surveying instruments.

Arrows

Arrows are made of good quality hardened steel wire of 4 mm diameter. The arrows are made 400 mm in length, are pointed at one end and the other end is bent into a loop or circle. Figure 3 shows the details of arrow.

Ranging rods

Ranging rods are used to range some intermediate points in the survey line. The length of the ranging rod is either 2 m or 3 m (Refer Figure 4). They are shod at bottom with a heavy iron point. Ranging rods are divided into equal parts 0.2 m long and they are painted alternately

black and white or red and white or red, white and black. When they are at considerable distance, red and white or white and yellow flags about 25 cm square should be fastened at the top.



Figure 3: Arrows

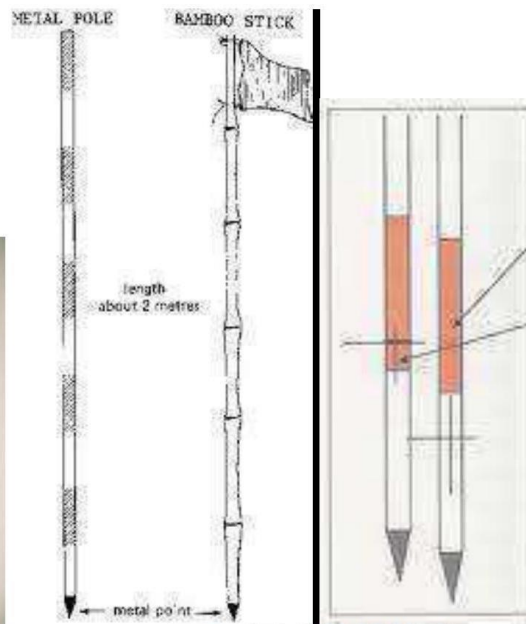

Figure 4: Ranging rods



Figure 5: Plumb Bob

Plumb-bob

A **plumb-bob** or a plummet is a weight, usually with a pointed tip on the bottom that is suspended from a string and used as a vertical reference line, or plumb-line. It is essentially the y -axis equivalent of a "water level". They are used with a variety of instruments (including level, theodolites, and steel tapes) to set the instrument exactly over a fixed survey marker, or to transcribe positions onto the ground for placing a marker (Refer Figure 5).

Pegs

These are rods made from hard timber and tapered at one end, generally 25 mm or 30 mm square and 150 mm long wooden pegs are used to mark the position of the station on.

Cross staff

The simplest instrument used for setting out a right angle. The common forms of cross staff are shown in Figure 6.



Figure 6: Metal cross staff Optical Square Wooden cross staff.

Calculations of Field Area: By this method of survey, the field as divided in to right angled triangles and trapezoids are calculated as under:

Area of right -angled triangle = $1/2 \text{ base} \times \text{Height}$.

Area of trapezoid= $\text{sum of parallel sides} / 2 \times \text{Height}$.

Add the areas of all the triangles & trapezoids and sum is equal to the total of a field.

The computations for area should be written in a tabular form as given below.

Sl. No.	Figure	Chainage in m .	Base in M.	Offset in M.	Mean offset in m .	Area in $\square^{\square} = \text{Col 4} \times \text{Col 6}$

Ranging out Survey Line

In measuring the length of a survey line called chain line, it is necessary that the chain should be laid out on the ground in a straight line between the end stations.

Ranging: "The process of establishing intermediate point on a straight line between two end points is known as ranging". Ranging must be done before a survey line is chained. It may be necessary to establish a number of intermediate points prior to chaining when chain line is much longer. Ranging may be done by direct observation by the naked eye or by line ranger or by Theodolite. Generally, ranging is done by naked eye with the help of three ranging rods. Ranging is of two kinds:

1. Direct Ranging
2. Indirect or reciprocal ranging
3. Direct Ranging: When intermediate ranging rods are fixed on a straight line by direct observation from end stations, the process is known as direct ranging. Direct ranging is possible when the end stations are intervisible. Assume that A and B two end stations of chain line (Refer Figure 7), where two ranging rods are already fixed. Suppose it is required to fix a ranging rod at the intermediate point P on the chain line in such a way that the points A, P & B are in same straight line. The surveyor stands about two meters behind the ranging rod at A by looking towards line AB. The assistant holds ranging rod at P vertically at arms length the rod should be held tightly by the thumb and forefinger. Now the surveyor direct the assistant to move the ranging rod to the left or right until the three ranging rods come exactly the same straight line. The ranging will be perfect, when the three ranging rods coincide and appear as a single rod. When the surveyor is satisfied that the ranging is perfect, he signals the assistant to fix the ranging rod on the ground. By following the same procedure, the other ranging rods may be fixed on the line.

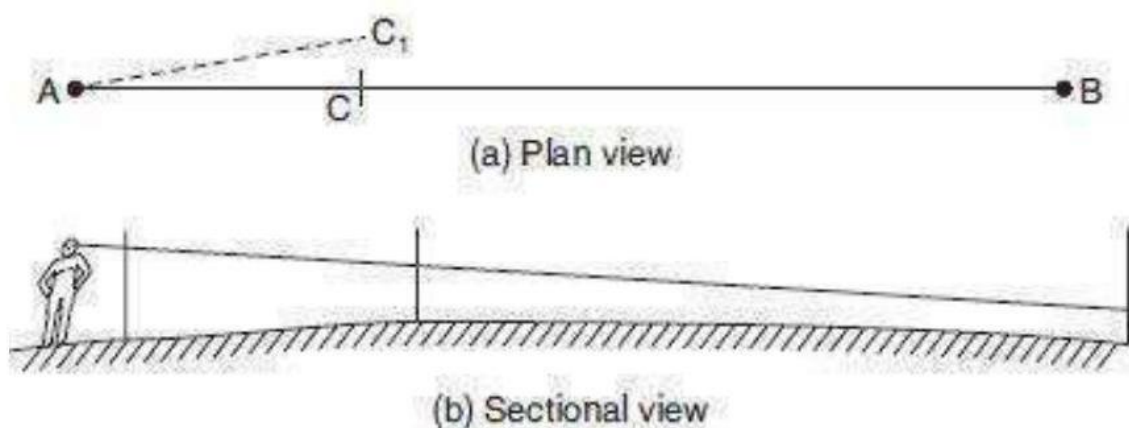

Figure 7: Direct Ranging

2. Indirect or Reciprocal Ranging: Indirect ranging is used when the end stations are not intervisible due to high ground or a hill or if the ends are too long. In such cases, intermediate points can be fixed on the survey line by a process known as reciprocal ranging. Let A & B be the two stations with rising ground or a hill (Refer Figure 8). Let two chainmen with ranging rods take up positions at M and P, such that, chainmen at M1 can see both rods at P1 and B and the chainmen at P1 can see the ranging rods at M1 and A. The chainmen at P1 directs the chainmen at M1 to shift the ranging rod at M2 in line with A and then chainman at M2 directs the

chainmen at P 1 to shift the ranging rod to P 2 in line with B , by successively directing each other to be in line with the end points. Their positions will be changed until finally they are both in line with $A&B$ exactly on line AB . Now the four ranging rods at $AMP&B$ are on same straight line. This method may also be used in ranging a line across a valley or river.

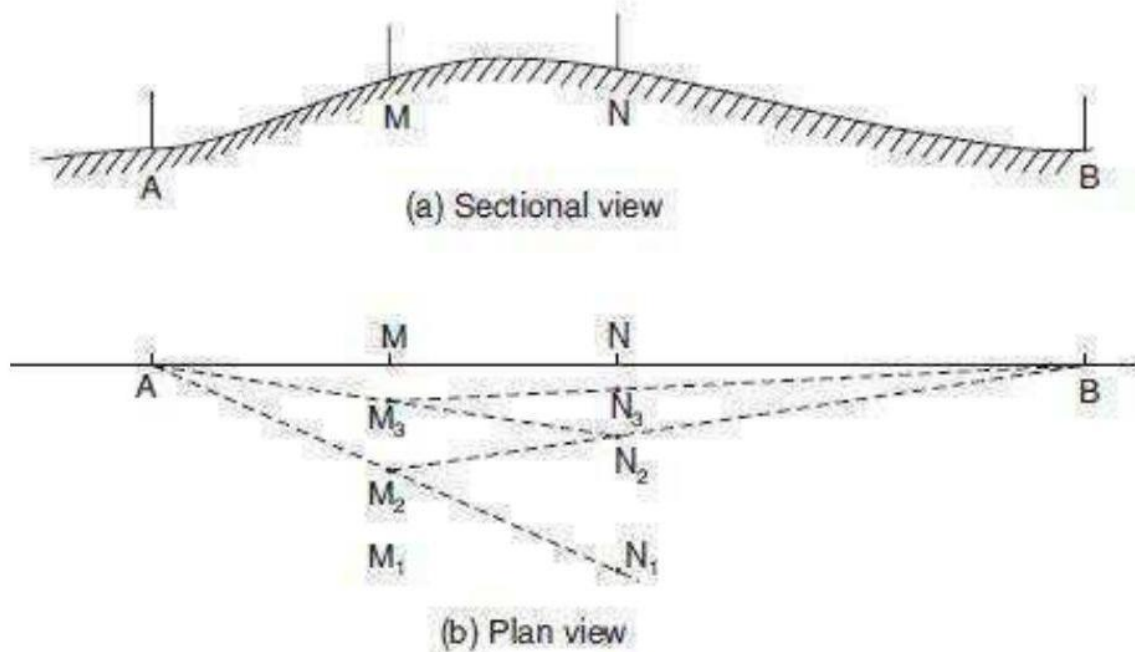

Figure 8: Indirect or Reciprocal Ranging

Survey Station

Survey stations are of two kinds

1. Main Stations
2. Subsidiary or tie

Main Stations: Main stations are the end of the lines, which command the boundaries of the survey, and the lines joining the main stations are called the main survey line or the chain lines.

Subsidiary or the tie stations: Subsidiary or the tie stations are the point selected on the main survey lines, where it is necessary to locate the interior detail such as fences, hedges, building etc.

Tie or subsidiary lines: A tie line joins two fixed points on the main survey lines. It helps to checking the accuracy of surveying and to locate the interior details. The position of each tie line should be close to some features, such as paths, building

etc.

Base Lines: It is main and longest line, which passes approximately through the centre of the field. All the other measurements to show the details of the work are taken with respect of this line.

Check Line: A check line also termed as a proof line is a line joining the apex of a triangle to some fixed points on any two sides of a triangle. A check line is measured to check the accuracy of the framework. The length of a check line, as measured on the ground should agree with its length on the plan.

Offsets:

These are the lateral measurements from the base line to fix the positions of the different objects of the work with respect to base line. These are generally set at right angle offsets. It can also be drawn with the help of a tape. There are two kinds of offsets:

1. Perpendicular offsets, and
2. Oblique offsets.

The measurements are taken at right angle to the survey line called perpendicular or right angled offsets. The measurements which are not made at right angles to the survey line are called oblique offsets or tie line offsets.

Plane Table Surveying

A plane table is a device used in surveying and related disciplines to provide a solid and level surface on which to make field drawings, charts and maps. It is a graphical method of surveying in which field work and plotting are done simultaneously in the field. It is very effective method of surveying for preparing small or medium size topographical plans. It is not as accurate as the other survey methods and results. It is particularly adopting in small mapping. Plane table surveying is used for locating the field computation of area of field.

Merits:

1. It is one of the most rapid methods of surveying.
2. Field notes are not required, and thus the possibility of mistakes in booking is eliminated.
3. Measuring of lines and angles is mostly dispensed with since they are obtained graphically.
4. Since the maps are plotted in the field, there is no chance of omitting necessary measurements.

5. The surveyor is fully confident about the true representation of the area since he can always compare his work with actual features on the ground and cannot, therefore, overlook any essential detail.
6. The surveyor can check the accuracy of his work more frequently and from any position he may desire, thus eliminating all the error at the spot.
7. It is particularly suitable for filling in details in hilly areas and in magnetic areas where chain and compass surveys are not suitable.
8. Contours and other irregular objects may be accurately represented on the map since the tract is in view.
9. It is less costly than Theodolite survey.
10. No great skill is required in making a satisfactory map and the work can be entrusted even to a subordinate.

Demerits:

- a. Plane Table Essentially a tropical instruments.
- b. It is not suitable to work in wet climate.
- c. There are several accessories to be carried out and therefore they are likely to be lost.
- d. It is not suitable for accurate work.

Plane table construction

A plane table consists of a smooth table surface mounted on the tripod. The mount allows the table to be leveled. The connection between the table top and the base permits one to level the table precisely, using bubble levels, in a horizontal plane. The base, a tripod, is designed to support the table over a specific point on land. By adjusting the length of the legs, one can bring the table level regardless of the roughness of the terrain.

Parts of plane Table:

Plane table essentially consists of Drawing board mounted on tripod and Alidade.

1. Drawing board mounted on tripod: A sheet of drawing paper, called plane table sheet is fastened to the board. Board is made up of well seasoned wood such as teak of size 40×30 to 75×60 cm. It had plane and smooth top. It is mounted on a tripod in manner that it can be leveled. Leveling up of the table is done by shifting the legs of tripod. Some tripod provided with leveling screw or by ball and socket head for accurate leveling.

2. Alidade: Alidade consists of two vertical sight vane fitted at end the end of straightedge. The straight edge ruler usually made of brass or teak wood graduated beloved edge. One of the sight veins is provided with narrow slit and the other with a central vertical wire or hair. Beveled working edge alidade is called fiducial edge.

Accessories:

- a. A trough campus for marking the direction magnetic meridian on paper.
- b. Sprit level for leveling the table.
- c. Forked plumb for centering the table.
- d. Water proof cover to protect the sheet from rain.

Centering: It is the process of keeping the table over the station that the point on the paper representing the station being occupied is vertically over the point on the ground. It is done by forked plumb bob.

Orientation: When the table has to be set up at more than one station it is necessary that it is be oriented so that the lines on the paper remain parallel to the lie which they represent on the ground. So orientation is "the process of keeping the table to the position which is occupied at the first station".

Orientation is done by two methods:

- a. By use of the magnetic needle.
- b. Orientation by back sighting.
 - a. Orientation by the magnetic needle: To orient the table at any subsequent station, the through compass(or circular box compass) is placed along the line representing the magnetic meridian which has been drawn on the paper at the first station, and the board is then turned until the ends of the needle olare opposite the zeros of the scale. The board is then clamped in position. It is suitable for rough small scale mapping.
 - b. Orientation by back sighting: This is the most accurate method of orientation and is always be preferred. Suppose a table is set up over station Q on the line PQ which ahs been previously drowned as PQ from station p . The alidade is placed along the line QP and board then turned until the line of sight bisects the ranging rod at P. Board is then properly clamped.



Figure 9: Plane table mounted on a tripod and Telescopic Alidade

Use of a plane table

In use, a plane table is set over a point and brought to precise horizontal level. A drawing sheet is attached to the surface and an alidade is used to sight objects of interest. The alidade, in modern examples of the instrument a rule with a telescopic sight, can then be used to construct a line on the drawing that is in the direction of the object of interest.

By using the alidade as a surveying level, information on the topography of the site can be directly recorded on the drawing as elevations. Distances to the objects can be measured directly or by the use of stadia marks in the telescope of the alidade.

Methods of Plane Table

1. Radiation
2. Intersection
3. Traversing
4. Resection
5. Radiation: This method is useful in surveying small areas which can be commanded from one station. From a station, the suitable is selected. Rays are drawn to various objects. The distance of the object from the station are measured and marked off on the ray.
6. Intersection: In this method, the positions of the object on the plan are fixed by the intersection of rays drawn from two instrument stations. The line joining these instrument stations are called baseline.
7. Traversing: This method is used for running survey lines for close or open traverse. This is the main method of plane table and is similar to compass or theodolite traversing. This method consists in running a traverse with a plane table; locating details by taking offsets in usual manner.
8. Resection: This method is used for establishing instrument station on a plan with reference to two points already plotted on the plan. The procedure adopted is as follows:

- a. Select the traverse stations say A, B, C etc.
- b. Set up the table over one of them say A. select the point A suitably on the sheet. Level and centre the table over A.
- c. Mark the direction of magnetic meridian on the top corner to the sheet by means of trough compass.
- d. With the alidade touching A, sight B and draw the ray.
- e. Measure the distance AB and scale off AB, thus fixing the position of B on the sheet which represents their station B on the ground.
- f. Shift the table and set up at B with *b* over B and orient it by placing. The alidade along BA, turning the table until the line of sight strikes A, and then clamp it.
- g. With the alidade touching B sight C and draw a ray.
- h. Measure the line BC and cut off BC to scale. Proceed similarly at other stations, in each case orienting by back side before taking forward sight until all the remaining stations are plotted.

Electronic Distance Measuring Instruments (EDM)

In surveying, the standard measurement device for many years remained the steel tape measure. Newer electronic measuring devices, however, have begun to take the place of the tape. In surveying applications, surveyors can take electronic distance measurements from helicopters covering distances and terrain that would have been near impossible with older methods. Laser distance meters in carpentry can measure any of the things carpenters used to use a tape measure for, and can send the measurements directly to a computer removing the possibility of forgotten or transposed numbers.

A distance measuring instrument is provided for simple field wise mapping of an area. The instrument comprises an electronic distance meter, a unit for determining a vertical angle for aligning the instrument with a measuring point, and a unit for obtaining a horizontal angle for the alignment of the instrument with a measuring point. The horizontal angle unit comprises a terrestrial magnetic-field detector which comprises at least two detector units fixedly mounted in the instrument. The units are directed in mutually different directions so that at least two components of the magnetic flux in an instrument-based coordinate system are obtained by the units. A calculating unit is arranged to convert the coordinates of the components of the terrestrial magnetic field from the instrument-based coordinate system to an earth-based coordinate system. The vertical angle obtained from the vertical angle unit is used for this conversion. The calculating unit is arranged to calculate the direction of the terrestrial magnetic field

in a horizontal plane and determine the horizontal angle relative to a reference direction.



Figure 10: EDM



Figure 11: Total station

Total station

A total station is an electronic/optical instrument used in modern surveying. The total station is an electronic theodolite (transit) integrated with an electronic distance meter (EDM) to read slope distances from the instrument to a particular point (see Figure 11). Robotic total stations allow the operator to control the instrument from a distance via remote control. This eliminates the need for an assistant staff member as the operator holds the reflector and controls the total station from the observed point.

Coordinate measurement: Coordinates of an unknown point relative to a known coordinate can be determined using the total station as long as a direct line of sight can be established between the two points. Angles and distances are measured

from the total station to points under survey, and the coordinates (X,Y, and Z or easting, northing and elevation) of surveyed points relative to the total station position are calculated using trigonometry and triangulation. To determine an absolute location a Total Station requires line of sight observations and must be set up over a known point or with line of sight to 2 or more points with known location.

For this reason, some total stations also have a Global Navigation Satellite System receiver and do not require a direct line of sight to determine coordinates. However, GNSS measurements may require longer occupation periods and offer relatively poor accuracy in the vertical axis.

Angle measurement: Most modern total station instruments measure angles by means of electro-optical scanning of extremely precise digital bar-codes etched on rotating glass cylinders or discs within the instrument. The best quality total stations are capable of measuring angles to 0.5 arc-second. Inexpensive "construction grade" total stations can generally measure angles to 5 or 10 arc-seconds.

Distance measurement: Measurement of distance is accomplished with a modulated microwave or infrared carrier signal, generated by a small solid-state emitter within the instrument's optical path, and reflected by a prism reflector or the object under survey. The modulation pattern in the returning signal is read and interpreted by the computer in the total station. The distance is determined by emitting and receiving multiple frequencies, and determining the integer number of wavelengths to the target for each frequency. Most total stations use purpose-built glass corner cube prism reflectors for the EDM signal. A typical total station can measure distances with an accuracy of about **1.5 mm + 2** parts per million over a distance of up to 1,500 m. Reflector less total stations can measure distances to any object that is reasonably light in color, up to a few hundred meters.

Data processing: Some models include internal electronic data storage to record distance, horizontal angle, and vertical angle measured, while other models are equipped to write these measurements to an external data collector, such as a hand-held computer.

When data is downloaded from a total station onto a computer, application software can be used to compute results and generate a map of the surveyed area. The new generation of total stations can also show the map on the touch-screen of the instrument right after measuring the points.

Applications:

a. Total stations are mainly used by land surveyors and Civil Engineers, either to

record features as in Topographic Surveying or to set out features (such as roads, houses or boundaries).

b. They are also used by archaeologists to record excavations and by police, crime scene investigators, private accident reconstructions and insurance companies to take measurements of scenes.

c. Mining: Total stations are the primary survey instrument used in mining surveying.

d. A total station is used to record the absolute location of the tunnel walls (stopes), ceilings (backs), and floors as the drifts of an underground mine are driven. The recorded data are then downloaded into a CAD program, and compared to the designed layout of the tunnel. The survey party installs control stations at regular intervals. These are small steel plugs installed in pairs in holes drilled into walls or the back. For wall stations, two plugs are installed in opposite walls, forming a line perpendicular to the drift. For back stations, two plugs are installed in the back, forming a line parallel to the drift. A set of plugs can be used to locate the total station set up in a drift or tunnel by processing measurements to the plugs by intersection and resection.

COMPASS SURVEY



Figure 12: Surveyors Compass



Figure 13: Prismatic Compass

A compass is a navigational instrument that shows directions in a frame of reference that is stationary relative to the surface of the earth. The frame of reference defines the four cardinal directions (or points) - north, south, east, and west. Intermediate directions are also defined. North corresponds to zero degrees, and the angles increase clockwise, so east is 90 degrees, south is 180, and west is 270.

1. Compass survey is a method of surveying by taking bearings and linear distances to produce plan.
2. Bearing is measured using prismatic compass, while the linear distance is measured using measuring tape.
3. Bearing in compass surveying means angle is made by chain line or survey line by referring it to magnetic meridian or magnetic north.

DEFINITION OF FEW COMPASS TERMS

MERIDIAN - it is the fixed direction in which the bearings of survey lines are expressed

BEARING - it is horizontal angle between the reference meridian and the survey line measured in clockwise or anticlockwise direction

TRUE MERIDIAN - The true meridian passing through a point on the earth surface is the line in which a plane passing through and the north and south poles, intersects the surface of the earth.

TRUE BEARING - The horizontal angle measured clockwise between the true meridian and the line is called true bearing of the line.

MAGNETIC MERIDIAN - the direction indicated by a freely suspended and balanced magnetic needle unaffected by local attractive forces

MAGNETIC BEARING - The horizontal angle which a line makes with the magnetic meridian.

DESIGNATION OF BEARINGS

The bearing is expressed in the following two ways:

1. Whole circle bearings
2. Quadrant bearings

WHOLE CIRCLE BEARING

The angle thus measured between the reference meridian and the line. It will have values between 0° and 360°

QUADRANTAL BEARING

The horizontal angle which a line makes with the north or south direction of the meridian whichever is nearer the line measured in the clockwise or counter clockwise direction. It will have value up to 90° .

TYPES OF COMPASS

There are two forms of compass in common use

1. The prismatic compass
2. The surveyor's compass

The prismatic compass is very valuable instrument and is commonly used for rough surveys where speed and not the accuracy is main consideration. The surveyor's

compass was formerly much used for land surveys but now-a-days, it is little used.

Differences between Prismatic compass and Surveyors compass:

Prismatic Compass (Refer Figure 13): The sighting of an object and reading of the bearing are done simultaneously. The graduated ring remains stationary as it is attached to magnetic needle. While the compass needle and the eye sight vane can be rotated. The graduations are made in such a way that 0 or 360 is at the south, 180 at north, 90 at south and 270 at east. Sighting of the object and the taking of reading is done simultaneously. Prismatic compass can be used without a tripod.

Surveyor's Compass (Refer Figure 14): An object is sighted first and the bearing is then read by going vertically over the middle point. The graduated ring being attached to the compass moves with sights. But needle remains stationary when box is rotated. The graduations are made as 00 at north & south 900 at east and west. The east and west positions are interchanged in order to read the bearing in quadrantal bearing system. Sighting the object is done first. Then the reading is to be taken with naked eye by looking above the needle point Surveyor's compass cannot be used without a tripod.

LOCAL ATTRACTION

Detection of local attraction: Local attraction at a place can be detected by observing bearings. If the fore and back bearings of the line differ exactly by 180° , there is no local attraction at either station provided instrumental and observational errors are eliminated. But if this difference is not equal to 180° , then local attraction exists there either at one or at both ends of the line. The list of materials which cause local attraction are:

- (i) Magnetic rock or iron ore,
- (ii) Steel structures, iron poles, rails, electric poles and wires,
- (iii) Key bunch, knife, iron buttons, steel rimmed spectacles, and
- (iv) Chain, arrows, hammer, clearing axe etc.

Surveyor is expected to take care to avoid local attractions listed in (iii) and (iv) above.

Correcting Observed Bearings:

If local attraction is detected in a compass survey observed bearings may be corrected by any one of the following two methods:

Method I: It may be noted that the included angle is not influenced by local attraction

as both readings are equally affected. Hence, first calculate included angles at each station, commencing from the unaffected line and using included angles, the corrected bearings of all lines may be calculated.

Method II: In this method, errors due to local attraction at each of the affected station is found starting from the bearing of a unaffected local attraction, the bearing of the successive lines are adjusted.

LEVELING

Leveling is the operation required in the determination or the comparison of heights of points on the surface of the earth. Leveling also is the procedure used when one is determining differences in elevation between points that are remote from each other. An elevation is a vertical distance above or below a reference datum. In land surveying, the reference datum is mean sea level (MSL).

Parts of Level (Refer Figure 15)

Objective lens - compound lens used to magnify object

Reticle - a pair of perpendicular reference lines that defines the line of sight, commonly called cross hairs

Negative lens - located between objective lens and reticle is used to bring object into focus on reticle plane

Eyepiece lens - Used to focus cross hairs (i.e. bring focus on cross hair plane)

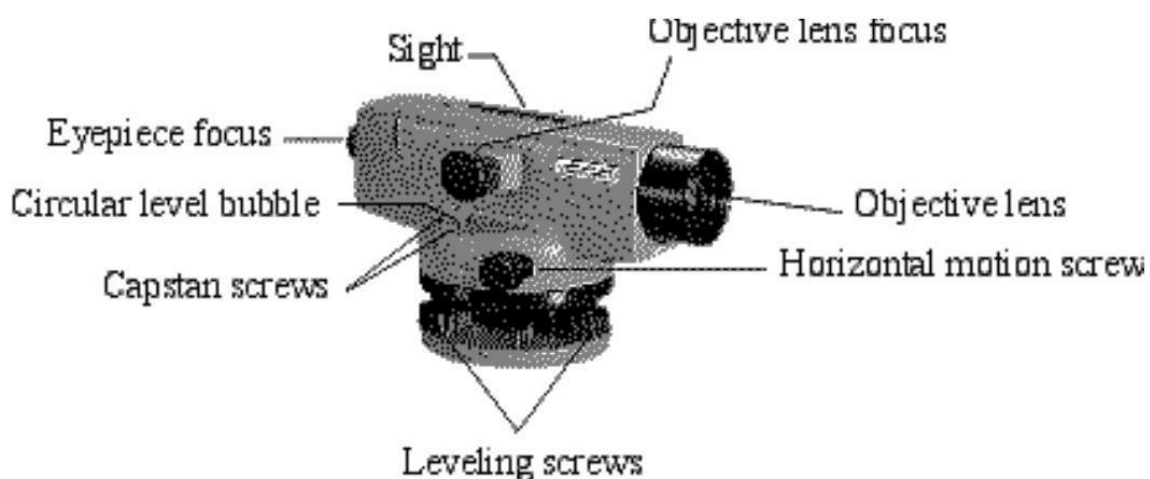

Figure 15: Parts of Level

Important: Lack of proper focus in object and eyepiece results in parallax, apparent shifting of object caused by motion of eye. Focus eyepiece and then object - check for parallax. Discuss this with your lab instructor.

Leveling screws - used to bring level instrument. Once leveled, the instrument's line of sight with scribe out a horizontal plane.

Circular level bubble - (aka bull's eye bubble) - 10' bubble used to bring automatic compensator into working range.

Level Vials: Level vials are used to orient surveying instruments with respect to the direction of gravity. Tube level vial is manufactured so that the inside of the glass lies along a sphere. The radius of curvature of this sphere determines the vial sensitivity. Longer radii are more sensitive and precise than shorter radii vials. Alternatively, it takes more time to center a bubble in a sensitive vial.

Rise and Fall Method

For the same set up of an instrument, Staff reading is more at a lower point and less for a higher point. Thus, staff readings provide information regarding relative rise and fall of

terrain points. This provides the basics behind rise and fall method for finding out elevation of unknown points.

With reference to Table when the instrument is at I_1 , the staff reading at $A(2.365\text{ m})$ is more than that at S_1 which indicates that there is a rise from station A to S_1 and accordingly the difference between them (1.130 m) is entered under the rise column in Table 1. To find the elevation of $S_1(101.130\text{ m})$, the rise (1.130 m) has been added to the elevation of $A(100.0\text{ m})$. For instrument set up at I_2 , S_1 has been treated as a point of known elevation and considered for back sight (having reading 0.685 m). Foresight is taken at S_2 and read as 3.570 m i.e., S_2 is at lower than \square_1 . Thus, there is a fall from \square_1 and \square_2 and there difference (2.885 m) is entered under the fall column in Table 13.1. To find the elevation of $\square_2(98.245\text{ m})$, the fall (2.885 m) has been subtracted from the elevation of $S_1(101.130\text{ m})$. In this way, elevations of points are calculated by Rise and fall method.

Level book note for Rise and Fall method

Points	Staff Reading		Difference in Elevation		Elevation	Remark
	B.S (m)	F.S.(m)	Rise (m)	Fall (m)	R.L (m)	
A	2.365				100.000	B.M.
S_1	0.685	1.235	1.130		101.130	T.P. 1
S_2	1.745	3.570		2.885	98.245	T.P. 2

B		2.340		0.595	97.650	
---	--	-------	--	-------	--------	--

Arithmetic Check for Reduction of Level

In case of Rise and Fall method for Reduction of level, following arithmetic checks are applied to verify calculations.

$$\Sigma \text{B.S.} - \Sigma \text{F.S.} = \Sigma \text{Rise} - \Sigma \text{Fall} = \text{Last R.L.} - \text{First R.L.}$$

With reference to Table 13.1:

$$\Sigma \text{B.S.} - \Sigma \text{F.S.} = 4.795 - 7.145 = -2.350$$

$$\Sigma \text{Rise} - \Sigma \text{Fall.} = 1.130 - 3.480 = -2.350$$

$$\text{Last R.L.} - \text{First R.L.} = 97.650 - 100.000 = -2.350$$

Height of Instrument Method

In any particular set up of an instrument height of instrument, which is the elevation of the line of sight, is constant. The elevation of unknown points can be obtained by subtracting the staff readings at the desired points from the height of instrument.

This is the basic behind the height of instrument method for reduction of level.

With reference to Table 2, when the instrument is at I_1 , the staff reading observed at A is 2.365 m . The elevation of the line of sight i.e., the height of instrument is 102.365 m obtained by adding the elevation of A(100.0 m) with the staff reading observed at A(2.365 m). The

elevation of S_1 (101.130 m) is determined by subtracting its foresight reading (1.235 m) from the height of instrument (102.365 m) when the instrument is at I_1 . Next, the instrument is set up at I_2 . S_1 is considered as a point of known elevation and back sight reading (0.685 m) is taken. The height of the instrument (101.815 m) is then calculated by adding back sight reading (0.685 m) with the elevation (R.L.) of point S_1 (101.130 m). Foresight is taken at S_2 and its elevation (98.245 m) is determined by subtracting the foresight (3.570 m) from the height of the instrument (101.815 m). In this way, elevations of points are calculated by Height of instrument method.

Level book note for Height of instrument method

Points	Staff Reading		Height of Instrument (m)	R.L. (m)	Remarks
	B.S (m)	F.S.(m)			
A	2.365		102.365	100.000	B.M.
S_1	0.685	1.235	101.815	101.130	T.P. 1

S_2	1.745	3.570		98.245	T.P. 2
B		2.340		97.650	

Arithmetic Check for Reduction of Level

In case of Height of instrument method for Reduction of level, following arithmetic checks are applied to verify calculations.

$$\Sigma \text{B.S.} - \Sigma \text{F.S.} = \text{Last R.L.} - \text{First R.L.}$$

With reference to Table 13.2:

$$\Sigma \text{B.S.} - \Sigma \text{F.S.} = 4.795 - 7.145 = -2.350$$

$$\text{Last R.L.} - \text{First R.L.} = 97.650 - 100.000 = -2.350$$

Example 2: Data from a differential leveling have been found in the order of B.S., F.S..... etc. starting with the initial reading on B.M. (elevation 150.485 m) are as follows : 1.205, 1.860, 0.125,1.915,0.395,2.615,0.880,1.760,1.960,0.920,2.595,0.915,2.255,0.515,2.305,1.170. The final reading closes on B.M. Put the data in a complete field note form and carryout reduction of level by Rise and fall method. All units are in meters.

Solution :

Level book note for Rise and Fall method

B.S. (m)	F.S. (m)	Rise (m)	Fall (m)	Elevation (m)	Remark
1.205				150.485	B.M.
0.125	1.860		0.655	149.830	
0.395	1.915		1.7290	148.040	

0.880	2.615		2.220	145.820	
1.960	1.760		0.880	144.940	
2.595	0.920	1.040		145.980	
2.255	0.915	1.680		147.660	
2.305	0.515	1.740		149.450	
	1.170	1.135		150.535	B.M.

Arithmetic Check for Reduction of Level

$$\Sigma \text{B.S.} = 11.720 \text{ m}; \Sigma \text{F.S.} = 11.670 \text{ m}$$

$$\text{Therefore } \Sigma \text{B.S} - \Sigma \text{F.S.} = 0.050 \text{ m}$$

$$\Sigma \text{Rise} = 5.595 \text{ m}; \Sigma \text{Fall} = 5.545 \text{ m}$$

$$\text{Therefore } \Sigma \text{Rise} - \Sigma \text{Fall} = 0.050 \text{ m}$$

$$\text{Last R.L.} - \text{First R.L.} = 150.535 - 150.485 = 0.050 \text{ m.}$$

$$\Sigma \text{B.S} - \Sigma \text{F.S.} = \Sigma \text{Rise} - \Sigma \text{Fall} = \text{Last R.L.} - \text{First R.L.}$$

Example 3: Data from a differential leveling have been found in the order of B.S., F.S..... etc. starting with the initial reading on B.M. (elevation 150.485 m) are as follows : 1.205, 1.860,

0.125,1.915,0.395,2.615,0.880,1.760,1.960,0.920,2.595,0.915,2.255,0.515,2.305,1.170.

The final reading closes on B.M. Put the data in a complete field note form and carry out reduction of level by Height of instrument method. All units are in meters.

Level book note for Height of instrument method

Points	Staff Reading		Height of Instrument (m)	R.L. (m)	Remarks
A	1.205		151.690	150.485	B.M.
S ₁	0.125	1.860	149.955	149.830	T.P. 1
S ₂	0.395	1.915	148.435	148.040	T.P. 2
B	0.880	2.615	146.700	145.820	
	1.960	1.760	146.900	144.940	
	2.595	0.920	148.575	145.980	
	2.255	0.915	149.915	147.660	
	2.305	0.515	151.705	149.400	
		1.170		150.535	

Arithmetic Check for Reduction of Level

$$\Sigma \text{B.S.} = 11.720 \text{ m}; \Sigma \text{F.S.} = 11.670 \text{ m}$$

$$\text{Therefore } \Sigma \text{B.S} - \Sigma \text{F.S.} = 0.050 \text{ m}$$

$$\text{Last R.L.} - \text{First R.L.} = 150.535 - 150.485 = 0.050 \text{ m.}$$

$$\Sigma B.S - \Sigma F.S. = \text{Last R.L.} - \text{First R.L.}$$

Example 4: A Leveling work is carried out from the point A to B and the readings are listed below. The instrument is shifted after 6th and 13th reading. Calculate the level difference between A and B . The RL of bench mark is 47.195, the first reading is taken to BM , the second reading is at A and the last reading is at B.

By Height of Instrument method:

Level book note for Height of instrument method

Staff Reading			Height of Instrument (m)	R.L. (m)	Remarks
1.575			48.770	47.195	BM
	1.250			47.520	A
	0.850			47.920	
	1.330			47.440	
	1.580			47.190	
2.550		1.450	49.870	47.320	CP1
	1.980			47.890	
	1.760			48.110	
	1.710			48.160	
	1.840			48.030	
	1.920			47.950	
1.830		3.250	48.450	46.620	CP2
		2.260		46.190	B

Level difference between A and B = 47.195 - 46.190=1.005.

Arithmetic Check for Reduction of Level

$$\Sigma B.S. = 5.955 \text{ m}; \Sigma F.S. = 6.960 \text{ m}$$

$$\text{Therefore } \Sigma B.S - \Sigma F.S. = -1.005 \text{ m}$$

$$\text{Last R.L.} - \text{First R.L.} = 46.190 - 47.195 = -1.005 \text{ m.}$$

$$\Sigma B.S - \Sigma F.S. = \text{Last R.L.} - \text{First R.L.}$$

By Rise and fall method:

Level book note for Rise and Fall method

Staff Reading			Rise	Fall	R.L. (m)	Remarks
B.S (m)	I.S.(m)	F.S.(m)				
1.575					47.195	BM
	1.250		0.325		47.520	A
	0.850		0.400		47.920	
	1.330			0.480	47.440	
	1.580			0.250	47.190	
2.550		1.450	0.130		47.320	CP1
	1.980		0.570		47.890	
	1.760		0.220		48.110	
	1.710		0.050		48.160	
	1.840			0.130	48.030	
	1.920			0.080	47.950	
1.830		3.250		1.330	46.620	CP2
		2.260		0.430	46.190	B

Level difference between A and $B = 47.195 - 46.190 = 1.005$.

Arithmetic Check for Reduction of Level

Σ B.S. = 5.955 m; Σ F.S. = 6.960 m

Therefore Σ B.S. - Σ F.S. = -1.005 m

Σ Rise = 1.695 m; Σ Fall = 2.700 m

Therefore Σ Rise - Σ Fall = -1.005 m

Last R.L. - First R.L. = 46.190 - 47.195 = -1.005 m.

Σ B.S. - Σ F.S. = Σ Rise - Σ Fall = Last R.L. - First R.L.

Example 5: The following consecutive readings were taken with a level and a 4.0 m staff on a continuously sloping ground at common interval of 30 m. 0.780, 1.535, 1.955, 2.430, 2.985, 3.480, 1.155, 1.960, 2.365, 3.640, 0.935, 1.045,

1.630 and 2.545. The reduced level of first point A was 180.750. Rule out a page of level field book and enter the above readings. Calculate the reduced levels of all the points and apply proper check for calculation. (June 2013)

Solution:

By Rise and fall method:

Level book note for Rise and Fall method

Staff Reading			Rise	Fall	R.L. (m)	Remarks
B.S (m)	I.S.(m)	F.S.(m)				
0.780					180.750	A
	1.535			0.755	179.995	
	1.955			0.420	179.575	
	2.430			0.475	179.100	
	2.985			0.555	178.545	
1.155		3.480		0.495	178.050	
	1.960			0.805	177.245	
	2.365			0.405	176.840	
0.935		3.640		1.275	175.565	
	1.045			0.110	175.455	
	1.630			0.585	174.870	
		2.545		0.915	173.955	

Arithmetic Check for Reduction of Level

$$\Sigma \text{B.S.} = 2.870 \text{ m}; \Sigma \text{F.S.} = 9.665 \text{ m}$$

$$\text{Therefore } \Sigma \text{B.S} - \Sigma \text{F.S.} = -6.795 \text{ m}$$

$$\Sigma \text{Rise} = 0.000 \text{ m}; \Sigma \text{Fall} = 6.795 \text{ m}$$

$$\text{Therefore } \Sigma \text{Rise} - \Sigma \text{Fall} = -6.795 \text{ m}$$

$$\text{Last R.L.} - \text{First R.L.} = 173.955 - 180.750 = -6.795 \text{ m.}$$

$$\Sigma \text{B.S} - \Sigma \text{F.S.} = \Sigma \text{Rise} - \Sigma \text{Fall} = \text{Last R.L.} - \text{First R.L.}$$

By Height of Instrument method:
Level book note for Height of instrument method

Staff Reading			Height of Instrument (m)	R.L. (m)	Remarks
B.S (m)	I.S.(m)	F.S.(m)			
0.780			181.530	180.750	A
	1.535			179.995	
	1.955			179.575	
	2.430			179.100	
	2.985			178.545	

1.155		3.480	179.205	178.050	
	1.960			177.245	
	2.365			176.840	
0.935		3.640	176.500	175.565	
	1.045			175.455	
	1.630			174.870	
		2.545		173.955	

Arithmetic Check for Reduction of Level

$$\Sigma \text{B.S.} = 2.870 \text{ m}; \Sigma \text{F.S.} = 9.665 \text{ m}$$

$$\text{Therefore } \Sigma \text{B.S} - \Sigma \text{F.S.} = -6.795 \text{ m}$$

$$\text{Last R.L.} - \text{First R.L.} = 173.955 - 180.750 = -6.795 \text{ m.}$$

$$\Sigma \text{B.S} - \Sigma \text{F.S.} = \Sigma \text{Rise} - \Sigma \text{Fall} = \text{Last R.L.} - \text{First R.L.}$$

Reciprocal Leveling: To find accurate relative elevations of two widely separated intervisible points (between which levels cannot be set), reciprocal leveling is being used.

To find the difference in elevation between two points, say X and Y , a level is set up at L near X and readings (X_1 and Y_1) are observed with staff on both X and Y respectively. The level is then set up near Y and staff readings (Y_2 and X_2) are

taken respectively to the near and distant points. If the differences in the set of observations are not same, then the observations are fraught with errors. The errors may arise out of the curvature of the earth or intervening atmosphere (associated with variation in temperature and refraction) or instrument (due to error in collimation) or any combination of these.

The true difference in elevation and errors associated with observation, if any, can be found as follows:

Let the true difference in elevation between the points be rh and the total error be e . Assuming, no error on observation of staff near the level (as the distance is very small)

Then,

$$rh = X_1 \sim (Y_1 - e) \text{ [From first set of observation]}$$

and

$$rh = (X_2 - e) \sim Y_2 \text{ [From second set of observation]}$$

$$\Delta h = [(X_1 \sim Y_1) + (X_2 \sim Y_2)]/2$$

$$\text{Or } \Delta h = [(\text{First difference in observation}) + (\text{Second difference in observation})]/2$$

Thus, the true difference in elevation between any two points can be obtained by taking the mean of the two differences in observation.

Thus, total error in observations can be obtained by taking the difference of the two differences in observation.

$$\text{Total error } e = [(X_1 \sim Y_1) - (X_2 \sim Y_2)]/2$$

$$\text{Or } e = [(\text{First difference in observation}) - (\text{Second difference in observation})]/2$$

The total error consist of error due to curvature of the earth, atmospheric errors (due to temperature and refraction) and instrumental errors (due to error in collimation) etc.

Theodolite

A theodolite is a precision instrument for measuring angles in the horizontal and vertical planes. Theodolites are used mainly for surveying applications, and have been adapted for specialized purposes in fields like metrology and rocket launch technology. A modern theodolite consists of a movable telescope mounted within two perpendicular axes-the horizontal or trunnion axis, and the vertical axis. When the telescope is pointed at a target object, the angle of each of these axes can be

measured with great precision, typically two seconds of arc. The most important instrument for exact survey work and many types are available to meet varying requirements of accuracy and precision, with direct readings of the circle ranging from 5 min to 0.1 sec.

CLASSIFICATION:

A. Theodolite may be classified into transit and non-transit theodolite.

Transit theodolite: A theodolite is said to be transit one when its telescope can be revolved through 180° in a vertical plane about its horizontal axis, thus directing the telescope in exactly opposite direction.

Non-transit theodolite: A theodolite is said to be a non-transit one when its telescope cannot be revolved through 180° in a vertical plane about its horizontal axis.

B. Based on the type the theodolite is divided into three types based on angles, which are vernier, optical and electronic.

Vernier Theodolite: Uses vernier scale

Optical Theodolite: Uses optical with horizontal and vertical circles made from transparent glasses and graduated scale.

Electronic Theodolite: Has a screen with digits for angles on front and back of the instrument.

The face of the current observation (telescope position) is the side on which the vertical circle is, when viewed from the eyepiece, which is either face left or face right. The telescope has its own clamp and tangent screws.

A theodolite is mounted on its tripod head by means of a forced centering plate or tribrach containing four thumbscrews, or in modern theodolites, three for rapid leveling. Before use, a theodolite must be precisely placed vertical above the point to be measured using a plumb bob, optical plummet or laser plummet. The instrument is then set level using levelling footscrews and circular and more precise tubular spirit bubbles.

Both axes of a theodolite are equipped with graduated circles that can be read through magnifying lenses. The vertical circle which 'transits' about the horizontal axis should read 90° (100 grad) when the sight axis is horizontal, or 270° when the instrument is in its second position, that is, "turned over" or "plunged". Half of the difference between the two positions is called the "index error".

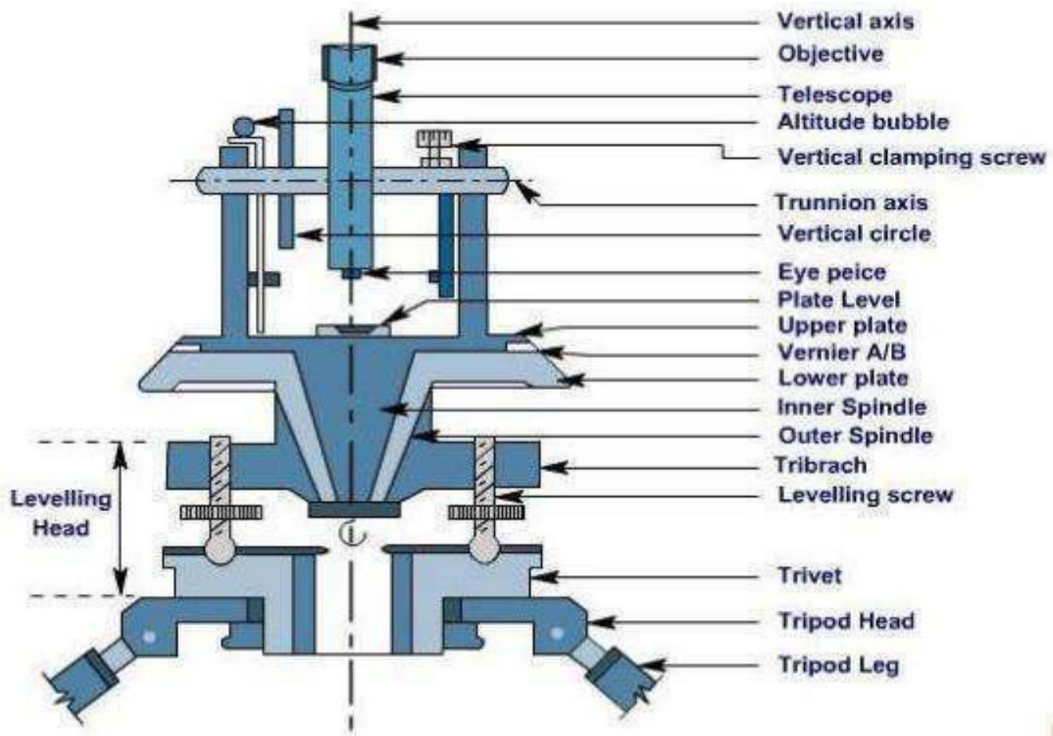

Sectional view of theodolite

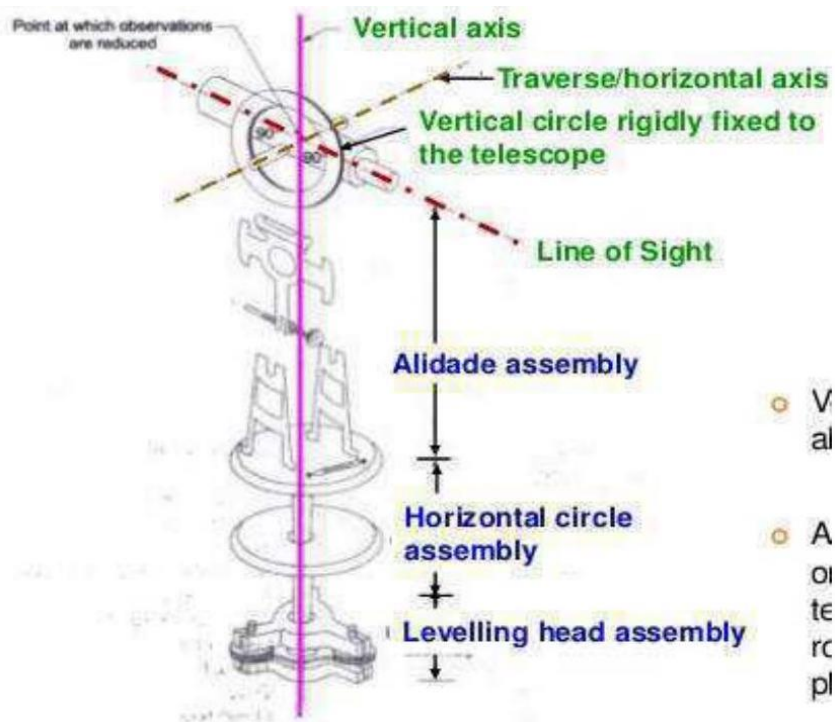

Three assemblies of theodolite



View of theodolite

Adjustment of a theodolite

The adjustments of a theodolite are of two kinds: Permanent adjustment and Temporary adjustment

PERMANENT ADJUSTMENT: The permanent adjustment are made to establish the fixed relationships between the fundamental lines of the instrument, and once made, they last for long time. They are essential for the accuracy of observations.

TEMPORARY ADJUSTMENT: The temporary adjustments are made at each set up

of the instrument before starting taking observations with the instrument. There are three temporary adjustment of a theodolite.

- a. Centering
- b. Levelling
- c. Focusing

a. **CENTERING:** Centering means bringing the vertical axis of the theodolite immediately over a station mark. The station mark should be represented by well-defined point such as end of a nail driven on the top of a peg or the intersection points of a cross marked at the surface below the instrument etc.

b. **LEVELLING:** Having centered and approximately leveled the instrument, it is accurately leveled with reference to the plate levels by means of foot-screws so that the vertical axis is made truly vertical.

c. **FOCUSSING:** This is done in two steps focusing of the eye-piece distinct vision of the crosshairs at diaphragm and focusing the object-glass for bringing the image of the object into the plane of the diaphragm.



If you have any queries please visit- <https://studywithakash.in/>

Gmail – studywithakash311@gmail.com

+918871317984

THANK YOU