

## UNIT- 4 FORCES & EQUILIBRIUM

**FORCES AND EQUILIBRIUM:** Graphical and Analytical Treatment of concurrent and non-concurrent Coplanar forces, force diagrams and Bow's notations, application to simple engineering structures and Components, method of joints, method of sections for forces in members of plan frames and trusses.

The branch of physical science that deals with the state of rest or the state of motion of the bodies under the action of different forces is termed as Mechanics.

### Classification of Engineering Mechanics:

Depending upon the body to which the mechanics is applied, the engineering mechanics is classified as

- (a) Mechanics of Solids, and
- (b) Mechanics of Fluids.

The mechanics of solids is further classified as mechanics of rigid bodies and mechanics of deformable bodies. The bodies which will not deform or the body in which deformation can be neglected in the analysis are called as rigid bodies. The mechanics of the rigid bodies dealing with the bodies at rest is termed as Statics and that dealing with bodies in motion is called Dynamics.

The dynamics dealing with the problems without referring to the forces causing the motion of the body is termed as Kinematics and if it deals with the forces causing motion also, is called Kinetics.

If the internal stresses developed in a body are to be studied, the deformation of the body should be considered. This field of mechanics is called Mechanics of Deformable Bodies/ Strength of Materials/Solid Mechanics. This field may be further divided into Theory of Elasticity and Theory of Plasticity.

Liquid and gases deform continuously with application of very small shear forces. Such materials are called Fluids. The mechanics dealing with behavior of such materials is called Fluid Mechanics. The classification of mechanics is summarized below in flow chart.

Engineering mechanics

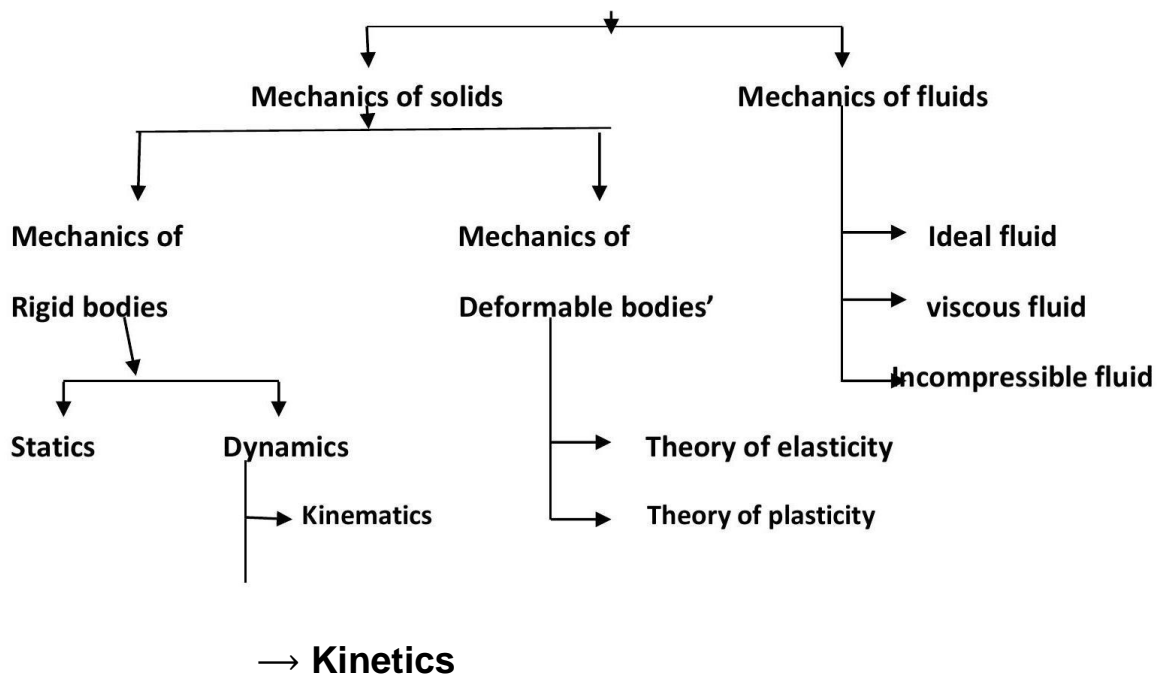

**Basic idealization in Mechanics:**

The following are the terms basic to study mechanics, which should be understood clearly:

**Mass:** The quantity of the matter possessed by a body is called mass. The mass of a body will not change unless the body is damaged and part of it is physically separated. When a body is taken out in a spacecraft, the mass will not change but its weight may change due to change in gravitational force. Even the body may become weightless when gravitational force vanishes but the mass remain the same.

**Continuum:** A body consists of several matters. It is a well-known fact that each particle can be subdivided into molecules, atoms and electrons. It is not possible to solve any engineering problem by treating a body as a conglomeration of such discrete particles. The body is assumed to consist of a continuous distribution of matter. In other words, the body is treated as continuum.

**Rigid Body:** In physics, a rigid body is an idealization of a solid body in which deformation is neglected. In other words, the distance between any two given points of a rigid body remains constant in time regardless of external forces exerted on it. Even though such an object cannot physically exist due to relativity, objects can normally be assumed to be perfectly rigid if they are not moving near the speed of light. In Figure 1 points *A* and *B* are the original position in a body. Many engineering problems can be solved satisfactorily by assuming bodies rigid.

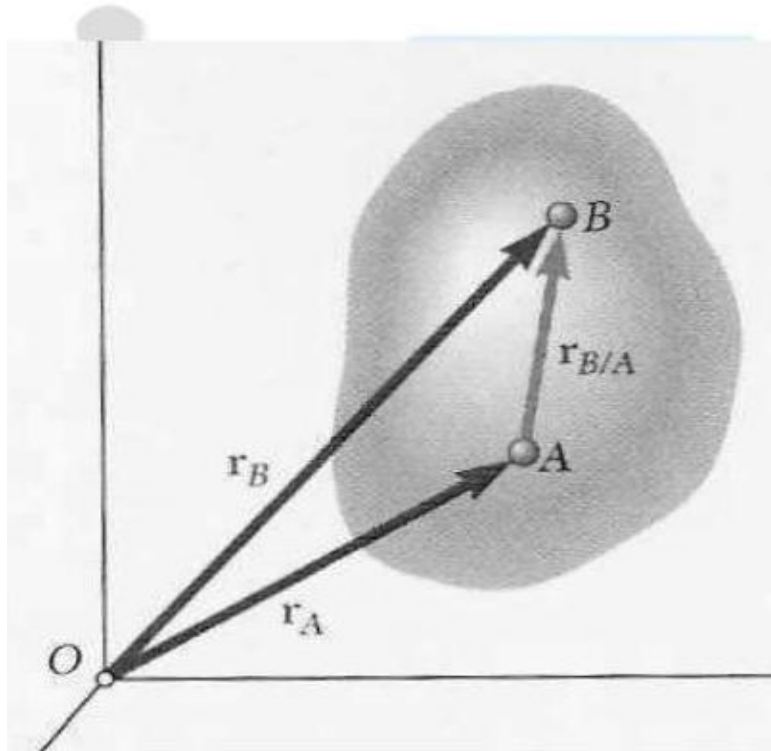

Figure 1: Rigid body concept.

## Particle

It is an object that has mass but no dimensions. Examples of such situations are

- A bomber airplane is a particle for a gunner operating from the ground.
- A ship in mid sea is a particle in the study of its relative motion from a control tower.
- In the study of movement of the earth in celestial sphere, earth is treated as a particle.

**Law of Transmissibility of Force:** According to this law the conditions of equilibrium or conditions of motion of a rigid body will remain unchanged if a force acting at a given point of the rigid body is replaced by a force of the same magnitude and same direction, but acting at a different point, provided that the two forces have the same line of action.

Let  $P$  be the force acting on a rigid body at point  $A$  as shown in Figure 2 below. According to the law of transmissibility of force, this force has the same effect on the state of body as the force  $P$  applied at point  $B$ .

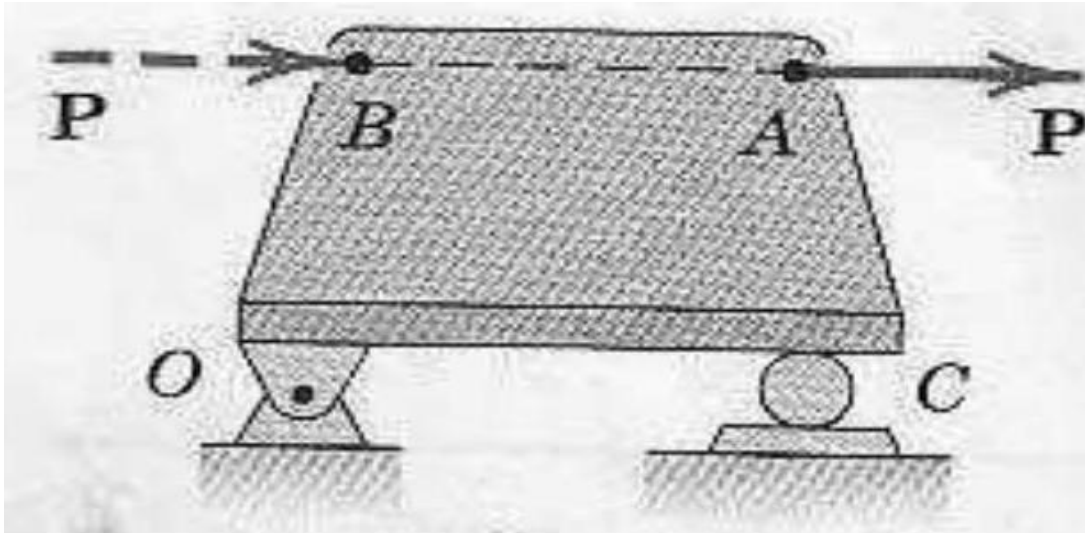

Figure 2: Principle of Transmissibility of forces.

**Composition of Forces:** The reduction of a given system of forces to the simplest system that will be its equivalent is called the problem of composition of forces.

**Resultant Force:** It is possible to find a single force which will have the same effect as that of a number of forces acting on a body. Such a single force is called resultant force. The process of finding out the resultant force is called composition of forces.

### Graphical methods:

#### Parallelogram Law of Forces:

The parallelogram law of forces enables us to determine the single force called resultant which can replace the two forces acting at a point with the same effect as that of the two forces. This law was formulated based on experimental results. This law states that if two forces acting simultaneously on a body at a point are presented in magnitude and direction by the two adjacent sides of a parallelogram, their resultant is represented in magnitude and direction by the diagonal of the parallelogram which passes through the point of intersection of the two sides representing the forces.

In Figure 4 the force  $P$  and force  $Q$  are acting on a body at point  $O$ . Then to get resultant of these forces parallelogram  $OACB$  is constructed such that  $OA$  is equal to  $P$  and  $OB$  is equal to  $Q$ . Then according to this law, the diagonal  $OC$  represents the resultant in the direction and magnitude. Thus the resultant of the forces  $P$  and  $Q$  on the body is equal to units corresponding to  $OC$  in the direction  $\alpha$  to  $P$ .

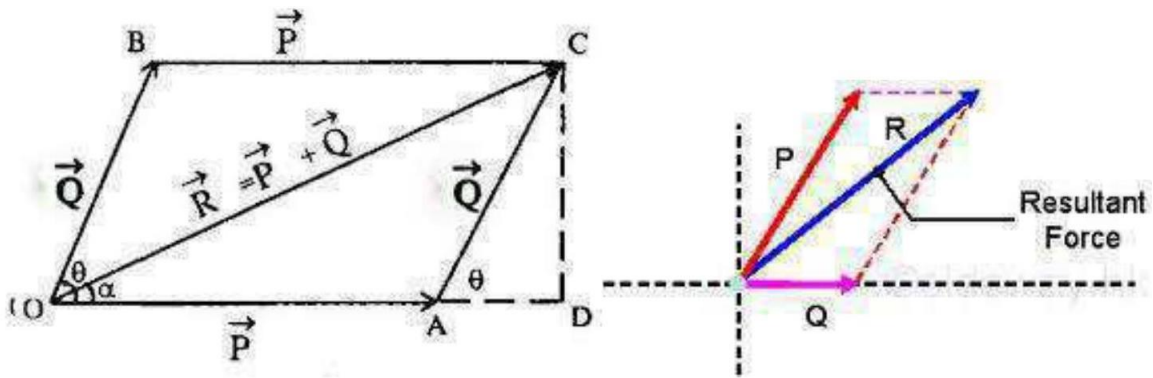

Figure 4: Parallelogram Law of Forces.

From Figure 4,  $\Sigma F_x = P + Q\cos\theta$   $\Sigma F_y = Q\sin\theta$

$$R = \sqrt{P^2 + Q^2 + 2PQ\cos\theta} \quad \alpha = \tan^{-1} \left[ \frac{Q\sin\theta}{P + Q\cos\theta} \right]$$

**Derived laws:**

Referring to Figure 5, we can get the resultant  $R$  by constructing the triangle. Line is drawn to represent  $F_1$  and line to represent  $F_2$ . Then the closing side of triangle should represent the resultant of  $F_1$  and  $F_2$ . Then we have derived triangle law of forces from fundamental law parallelogram law of forces. The Triangle Law of Forces may be stated as If two forces acting on a body are represented one after another by the sides of a triangle, their resultant is represented by the closing side of the triangle taken from first point to the last point.

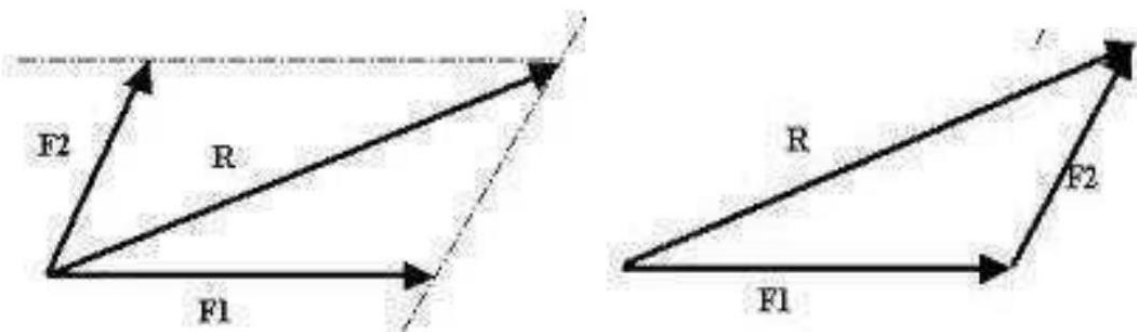

Figure 5: Triangle Law of Forces.

If more than two concurrent forces are acting on a body, two forces at a time can be combined by triangle law of forces and finally resultant of all the forces acting on the body may be obtained.

A system of four concurrent forces acting on a body is shown in Figure 6.  $AB$  represents  $P$  and  $BC$  represents  $Q$ ,  $CD$  represents  $S$  and  $DE$  represents  $T$ . Hence

according to triangle law of forces  $AC$  represents the resultant of  $P$  and  $Q$ ,  $AD$  represents the resultant of  $P, Q$  and  $S$ .  $AE$  represents the resultant of  $P, Q, S$  and  $T$ . Thus resultant  $R$  is represented by the closing line of the polygon  $ABCDE$  in the direction  $AE$ . Thus we have derived polygon of law of forces and it may be stated as "If a number of concurrent forces acting simultaneously on a body are represented in magnitude and direction by the sides of a polygon, taken in a order, then the resultant is represented in magnitude and direction by the closing side of the polygon, taken from first point to last point.

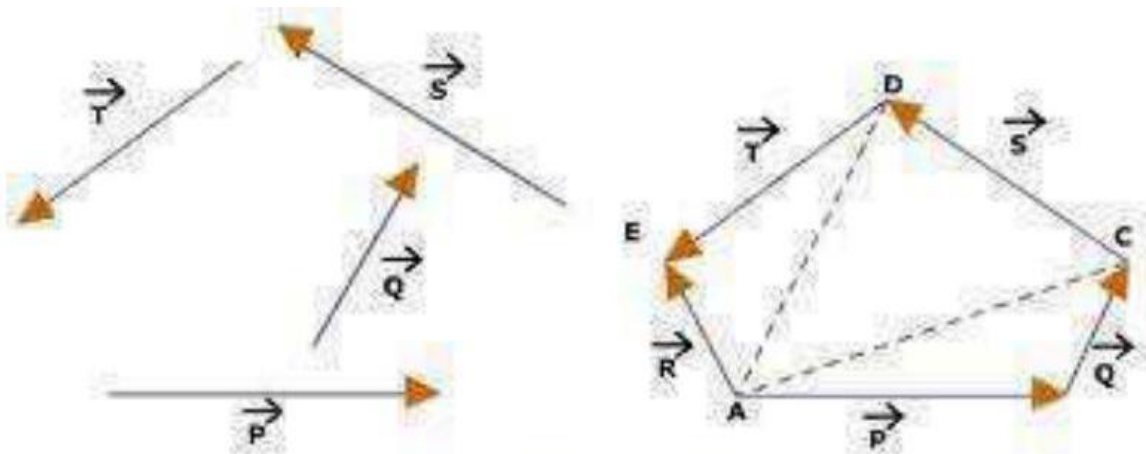

Figure 6: Triangle Law of Forces.

### Resolving Forces, Calculating Resultants

Resolving forces refers to the process of finding two or more forces which, when combined, Produce a force with the same magnitude and direction as the original. The most common use of the process is finding the components of the original force in the Cartesian coordinate directions  $x$  and  $y$ . Breaking down a force into its Cartesian coordinate components (e.g.,  $F_x$ ,  $F_y$ ) and using Cartesian components to determine the force and direction of a resultant force are common tasks when solving statics problems. These will be demonstrated here using a two-dimensional problem involving coplanar forces.

Example:

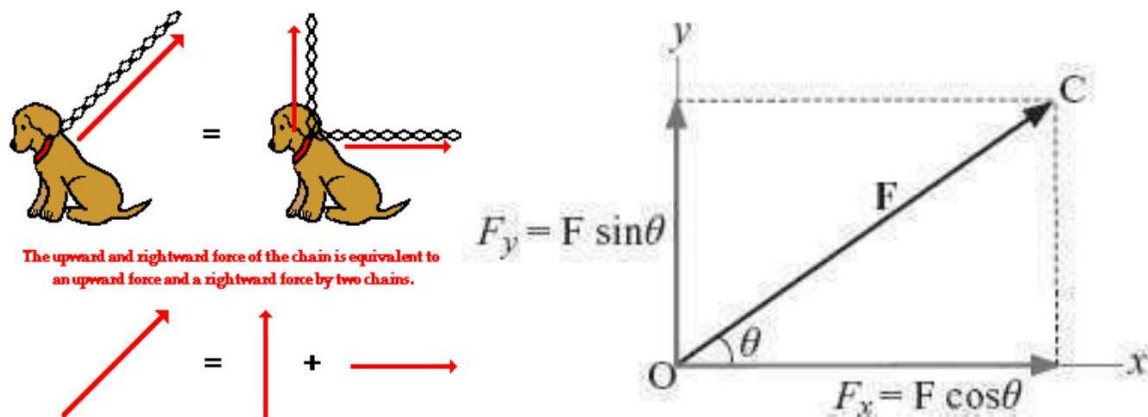

Figure 7: Rectangular components of Forces.

If the force  $F$  is resolved into two components which are perpendicular to each other, then these are called rectangular components  $F_x$  and  $F_y$  (Figure 7)

Units:

Length ( $L$ ), Mass ( $M$ ) and Time ( $S$ ) are the fundamental units in mechanics. The units of all other quantities may be expressed in terms of these basic units. The three commonly used systems in engineering are

- Meter-Kilogram-Second (MKS) system
- Centimeter-Gram-Second (CGS) system, and
- Foot-Pound-Second (FPS) system.

The units of length, mass and time used in the system are used to name the systems. Using these basic units, the units for other quantities can be found. For example, in MKS the units for the various quantities are as shown below:

Area Square meter  $\text{m}^2$ , Volume Cubic meter  $\text{m}^3$ , Velocity Meter per second  $\text{m}/\text{sec}$ , Acceleration Meter per second per second  $\text{m}/\text{sec}^2$ .

**Unit of Force:** Presently the whole world is in the process of switching over to SI system of units. SI stands for System International units or International System of units. As in MKS system, in SI system also the fundamental units are meter for length, kilogram for mass and second for time. The difference between MKS and SI system arise mainly in selecting the unit of force.

We know that **Force = Mass  $\times$  Acceleration**

In SI system unit of force is defined as that force which causes 1 kg mass to move with an acceleration of  $1\text{m}/\text{sec}^2$  and is termed as 1 Newton. Unit of force can be derived as

**Unit of Force =  $\text{kg} \times \text{m}/\text{sec}^2 = \text{kg} - \text{m}/\text{sec}^2 = 1\text{N}$ .**

The weight of 1 kg mass is mg which is equal to  $9.81 \times 1 \text{ kg m/s}^2 = 9.81 \text{ N}$ .

The prefixes used in SI system when quantities are too big or too small are shown in Table 1.1.

Table 1.1: Prefixes and Symbols of Multiplying Factors in SI

Multiplying Factor	Prefix	Symbol
$10^{12}$	tera	T
$10^9$	giga	G
$10^6$	mega	M
$10^3$	kilo	k
$10^0$	--	--
$10^{-3}$	milli	m
$10^{-6}$	micro	$\mu$
$10^{-9}$	nano	n
$10^{-12}$	pico	p
$10^{-15}$	femto	f
$10^{-18}$	atto	a

### Characteristics of force:

From Newton's first law, we defined the force as the agency which tries to change state of stress or state of uniform motion of the body. From Newton's second law of motion we arrived at practical definition of unit force as the force required producing unit acceleration in a body of unit mass. Thus 1 Newton is the force required to produce an acceleration of  $1 \text{ m}/\text{sec}^2$  in a body of 1 kg mass. It may be noted that a force is completely specified only when the following four characteristics are specified:

### - Magnitude

- Point of application
- Line of action, and
- Direction

In the example shown below;

Magnitude of the three forces is **100 N**.

Point of application is **A** .

Line of action is a line passing through **A** and along the force.

Direction is **30°** with horizontal.

Figure 7: Characteristics of Forces.

In Figure 8 a ladder is kept against a wall and horizontal floor. At point **C**, a person weighing 800 N is standing. The force applied by the person on the ladder has the following characteristics:

- Magnitude is 800 N
- The point of application is at **C** which is **x** m from **A** along the ladder.
- The line of action is vertical, and
- The direction is downward.

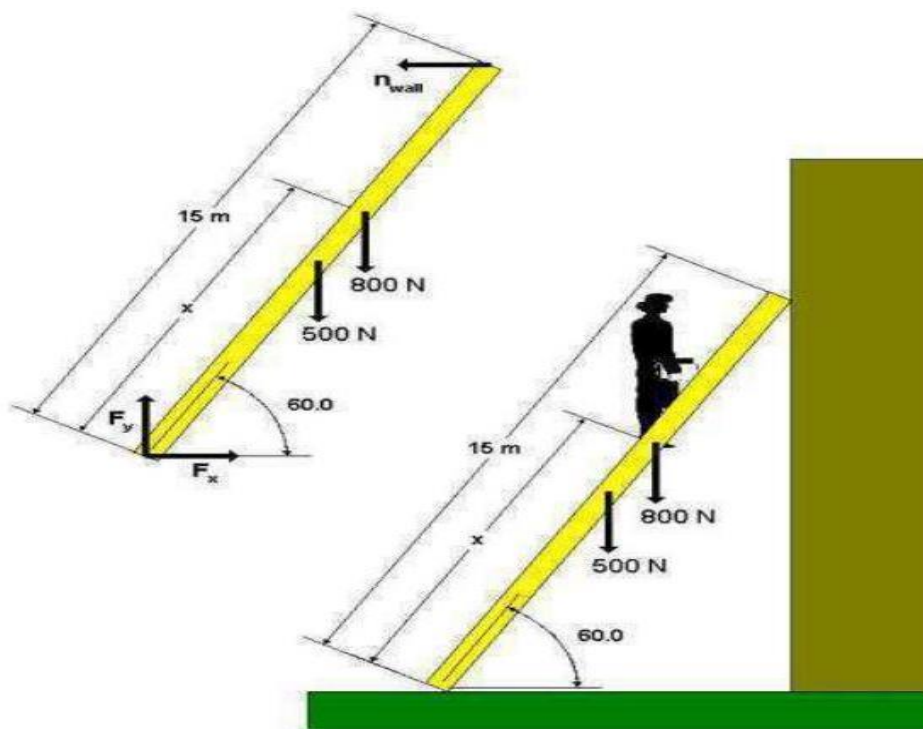

Figure 8: Forces in Ladder.

**System of Forces:**

When several forces act simultaneously on a body, they constitute a system of forces. If all the forces in a system do not lie in a single plane they constitute the system of forces in space. If all the forces in a system lie in a single plane, it is called a coplanar force system. If the line of action of all the forces in a system passes through a single point, it is called a concurrent force system. In a system of parallel forces all the forces are parallel to each other. If the line of action of all the forces lies along a single line then it is called a collinear force system. Various system of forces, their characteristics and examples are given in Table 1.2 and shown in Fig. 9

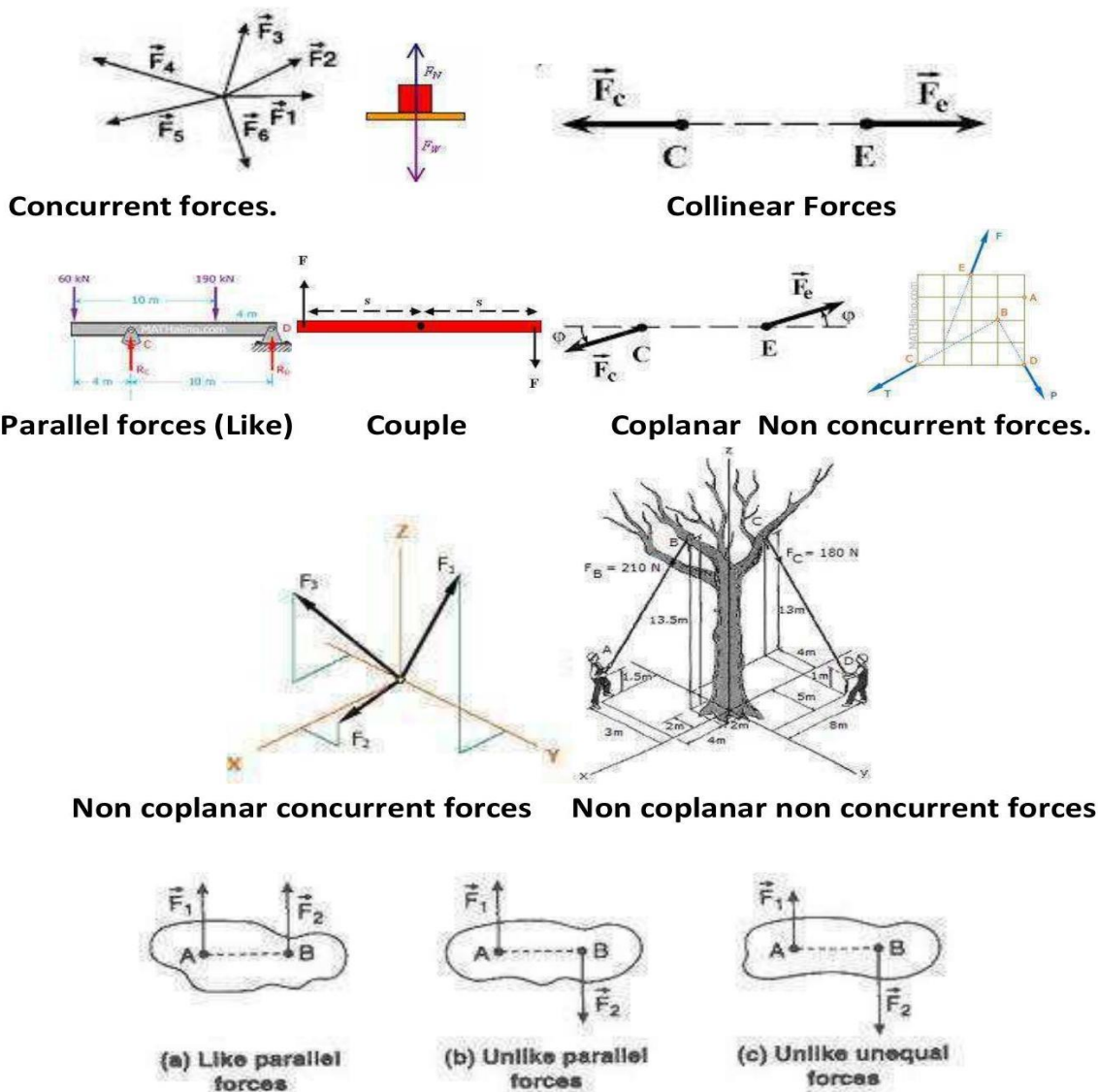

Figure 9: Types of Forces.

Table 1.2: System of Forces

Force System	Characteristics	Examples
Coplanar parallel forces	All forces are parallel to each other and lie in a single plane.	Forces on a rope in a tug of war.
Coplanar like parallel forces	All forces are parallel to each other, lie in a single plane and are	System of forces acting on a beam subjected to vertical

	acting in the same direction.	loads (including reactions).
Coplanar concurrent forces	All forces lie in the same plane, but their lines of action pass through a single point.	Weight of a stationary train on a rail when the track is straight.
Collinear forces	Line of action of all the forces act along the same line.	Forces on a rod resting against a wall.
Coplanar non-concurrent forces	All forces do not meet at a point, but lie in a single plane.	Forces on a ladder resting against a wall when a person stands on a rung which is not at its centre of gravity.
Non-coplanar parallel forces	All the forces are parallel to each other, but not in same plane.	The weight of benches in a classroom.
Non-coplanar concurrent forces	All forces do not lie in the same plane, but their lines of action pass through a single point.	A tripod carrying a camera.
Non-coplanar nonconcurrent forces	All forces do not lie in the same plane and their lines of action do not pass	Forces acting on a moving bus.

through a single point.

**Free Body Diagram:**

A free-body diagram is a sketch of an object of interest with all the surrounding objects stripped away and all of the forces acting on the body shown. A free body diagram, sometimes called a force diagram, is a pictorial device, often a rough working sketch, used by engineers and physicists to analyze the forces and moments acting on a body. The body itself may consist of multiple components, an automobile for example, or just a part of a component, a short section of a beam for example, anything in fact that may be considered to act as a single body, if only for a moment. A whole series of such diagrams may be necessary to analyze forces in a complex problem. The free body in a free body diagram is not free of constraints, it is just that the constraints have been replaced by arrows representing the forces and moments they generate.

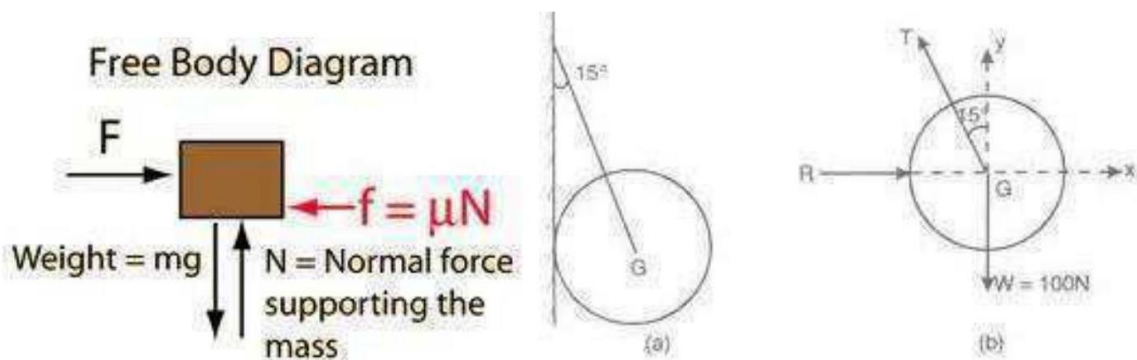

Subject Name: Basic Civil Engineering & Engineering Mechanics

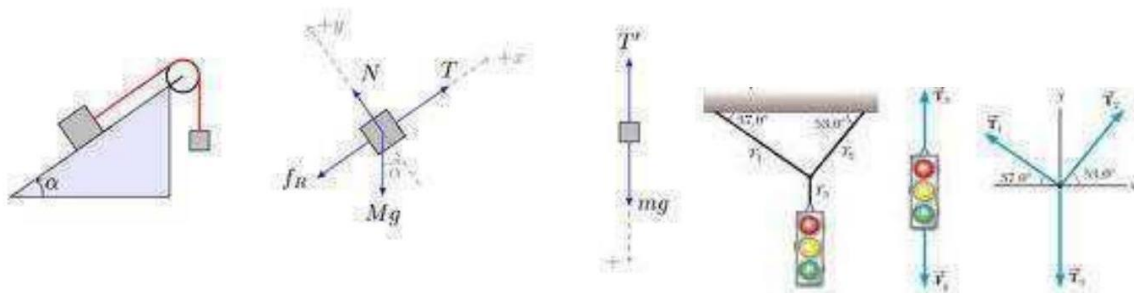

Figure 10: Examples for Free Body diagram.

**Resultant of concurrent forces:**

The resultant force can be obtained by resolving the force in to rectangular components along x and y axis.

The magnitude of resultant force is given by  $R = \sqrt{(\sum F_x)^2 + (\sum F_y)^2}$

The inclination of resultant force with x axis is given by the equation

$$\Theta_x = \tan^{-1} \left[ \frac{\sum F_y}{\sum F_x} \right]$$

Where  $\sum F_x$  = Algebraic sum of x components of all forces.

$\sum F_y$  = Algebraic sum of y components of all forces. (Refer Figure 11)

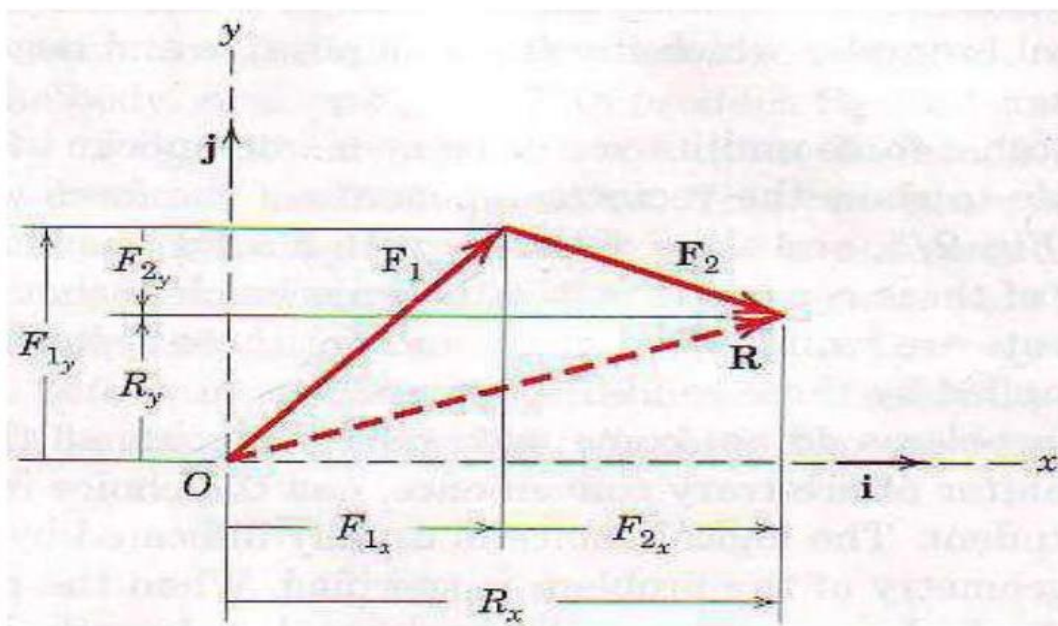

Figure: Resultant of concurrent force systems.

**Equilibrant of concurrent forces:**

Mathematically  $E = -R$

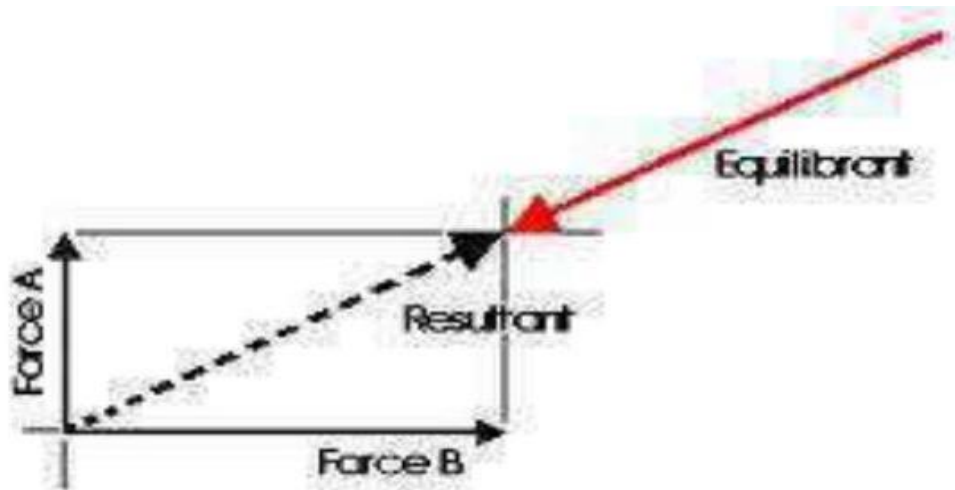

Figure: Equilibrant of concurrent force systems.

### Moment of a Force

The Moment of a force is the turning effect about a pivot point. To develop a moment, the force must act upon the body to attempt to rotate it. A moment can occur when forces are equal and opposite but not directly in line with each other.

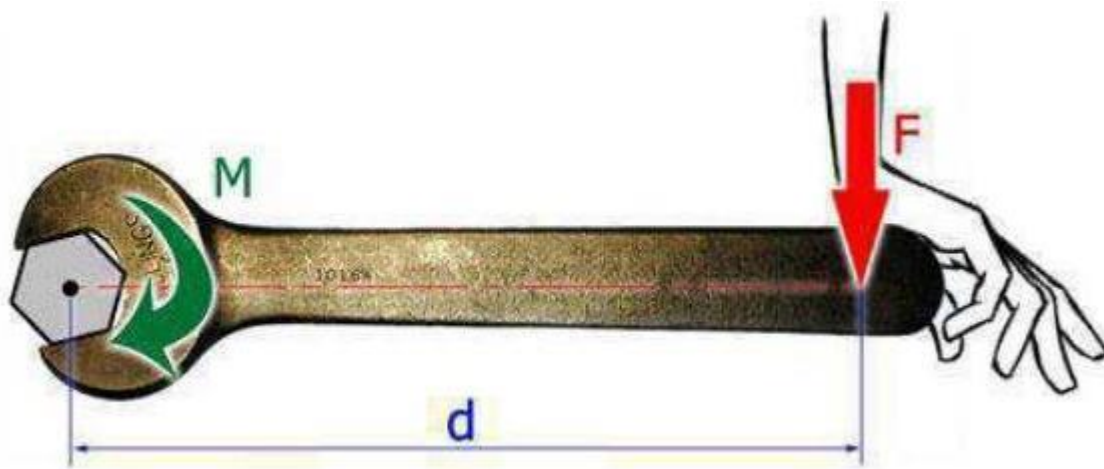

Figure: Moment of a force.

The Moment of force acting about a point or axis is found by multiplying the Force ( $F$ ) by the perpendicular distance from the axis ( $d$ ), called the lever arm.

Moment = Force x Perpendicular Distance

$M = F \times d$ , Unit is Newton meter (Nm).

## Force Couples

Two equal forces of opposite direction, with a distance  $d$  between them will cause a moment, where; a special case of moments is a couple. A couple consists of two parallel forces that are equal in magnitude, opposite in sense and do not share a line of action. It does not produce any translation, only rotation. The resultant force of a couple is zero, but it produces a pure moment. A tap wrench is an example of a couple. The two hand forces are equal but opposite direction. Taking moments about the centre (both clockwise); Moment =  $F * d + F * d = 2Fd$

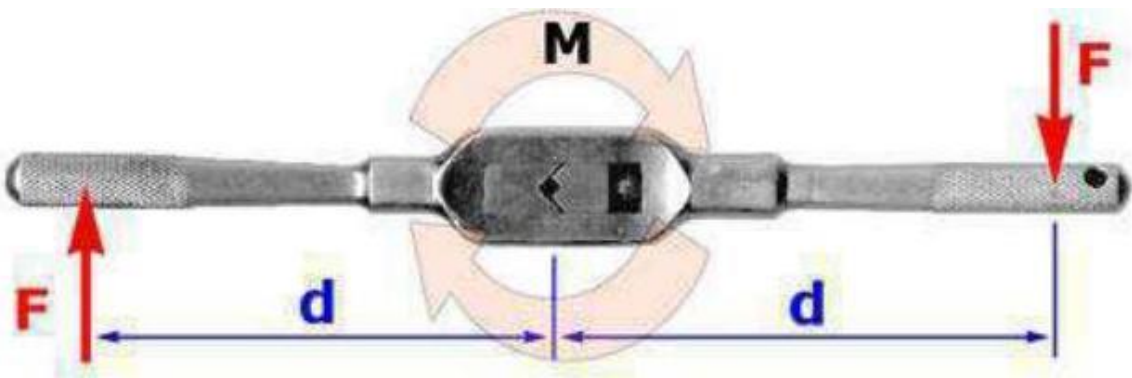

Figure: Couples.

The moment caused by a couple = the force \* the distance between them.

Principle of Moments (Varignon's Theorem) The Principle of Moments, also known as Varignon's Theorem, states that the moment of any force is equal to the algebraic sum of the moments of the components of that force.

Proof of Varignon's theorem:

Let us consider any point 'O' lying in the plane of the forces, as a moment center.

Now, Moment of force  $P$  about  $O$  will be  $Pd = P(OA \cos \theta) = OA(P \cos \theta) = OA \times P_x(1)$

Moment of force  $P_1$  about  $O$ .

$$P_1d_1 = P_1(OA \cos \theta_1) = OA(P_1 \cos \theta_1) = OA \times P \times 1 \quad (2)$$

Moment of force  $P_2$  about  $O$ .

$$P_2d_2 = P_2(OA \cos \theta_2) = OA(P_2 \cos \theta_2) = OA \times P \times 2 \quad (3)$$

Adding eq. (2) and (3)

$$P_1d_1 + P_2d_2 = OA (P_x1 + P_x2)$$

But  $P_x = P_{x1} + P_{x2}$

The sum of  $x$ -components of the forces  $P_1$  and  $P_2 = x$ -components of the resultant  $P$ .

$\therefore OA \times P_x = P_1 d_1 + P_2 d_2$

From eq. (1) we see that  $OA \times P_x = Pd$

$\therefore Pd = P_1 d_1 + P_2 d_2$  Hence proved

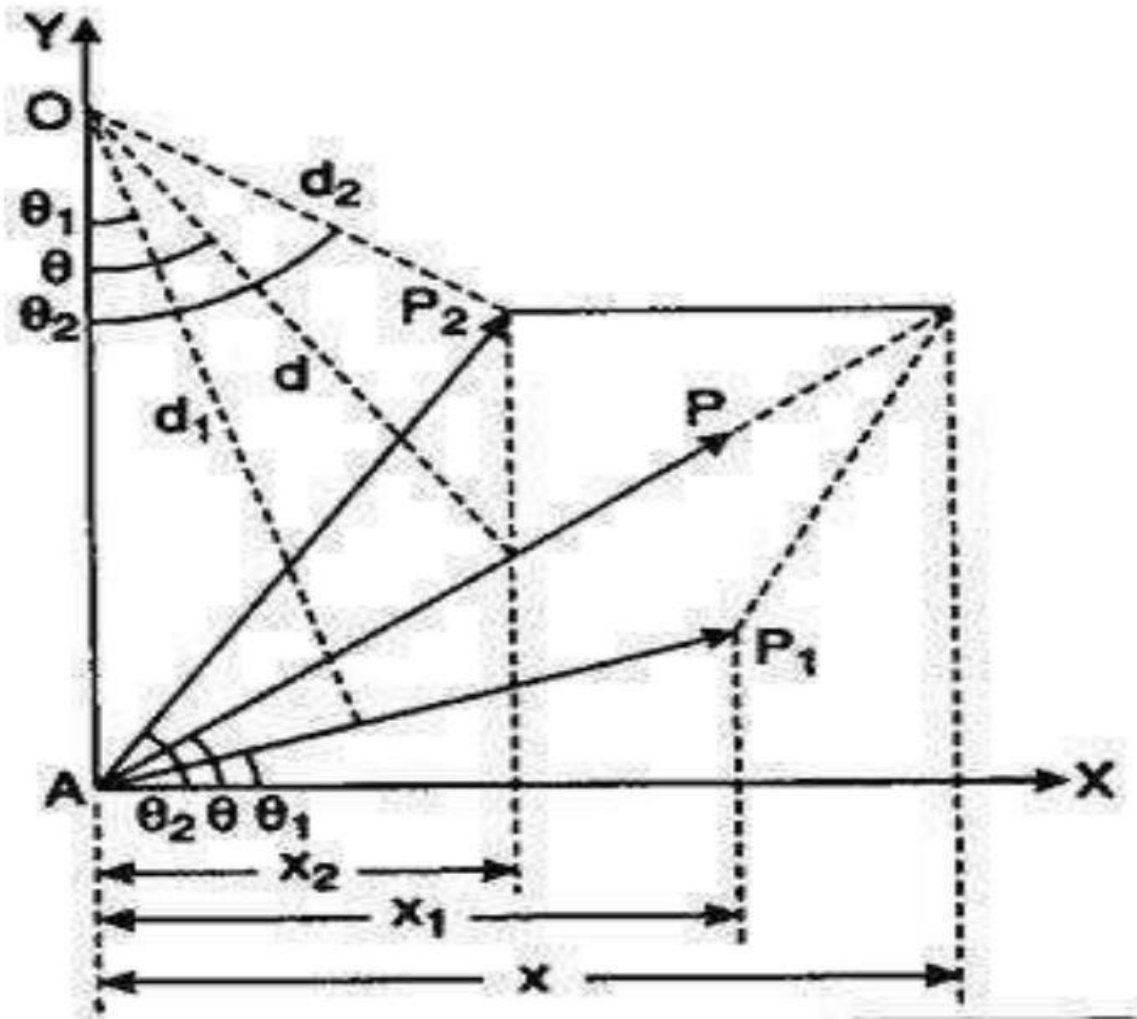

Figure: Varignon's theorem of moments.

Resultant of non-concurrent forces:

The resultant force can be obtained by resolving the force in to rectangular components along  $x$  and  $y$  axis.

The magnitude of resultant force is given by  $R = \sqrt{(\sum F_x)^2 + (\sum F_y)^2}$

The inclination of resultant force with  $x$  axis is given by the equation

$$\theta_x = \tan^{-1} \left[ \frac{\sum F_y}{\sum F_x} \right]$$

Where  $\sum F_x =$  Algebraic sum of  $x$  components of all forces.

$\sum F_y =$  Algebraic sum of  $y$  components of all forces.

The point of application of resultant force is obtained by applying the principle of moments.

Equilibrium of concurrent forces:

In the equilibrium of concurrent force system the resultant force is equal to zero.

Resultant force =  $R = 0$ ;

$$\sum F_x = 0$$

$$\sum F_y = 0$$

Where  $\sum F_x =$  Algebraic sum of  $x$  components of all forces.

$\sum F_y =$  Algebraic sum of  $y$  components of all forces.

The above conditions are also called as static equilibrium conditions for concurrent force system.

Equilibrium of non-concurrent forces:

In the equilibrium of non-concurrent force system the resultant force and resultant moment are equal to zero.

Resultant force =  $R = 0$ ;

$$\sum F_x = 0$$

$$\sum F_y = 0$$

Resultant moment = 0;

$$\sum M_A = 0$$

Where  $\sum F_x =$  Algebraic sum of  $x$  components of all forces.

$\sum F_y =$  Algebraic sum of  $y$  components of all forces.

$\sum M_A =$  Algebraic sum of moments of all forces with respect to any point A.

The above conditions are also called as static equilibrium conditions for non-concurrent force system.

**Problems on Resultant of Coplanar concurrent forces:**

**Problem 01:** Determine the resultant force of the force system as shown in figure 1(P: 01).

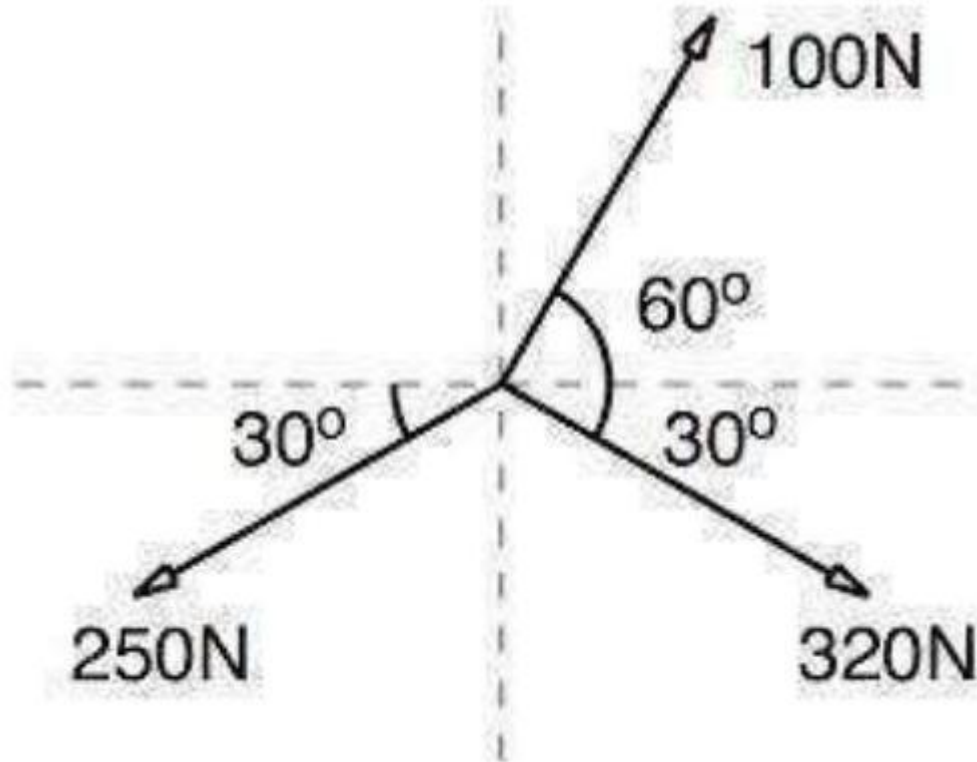

Figure: (P: 01)

**Solution:**

$$\begin{aligned}\Sigma F_x &= R_x \\ &= 100\cos 60 - 250\cos 30 + 320\cos 30 \\ &= 50.00 - 216.51 + 277.13 \\ &= 110.62 \text{ N}\end{aligned}$$

$$\begin{aligned}\Sigma F_y &= R_y \\ &= 100\sin 60 - 250\sin 30 - 320\sin 30 \\ &= 86.60 - 125.00 - 160.00 \\ &= -198.40 \text{ N}\end{aligned}$$

$$R = \sqrt{110.62^2 + 198.40^2} = 227.15 \text{ N}$$

$$\begin{aligned}\Theta_x &= \tan^{-1} 198.40/110.62 = 60.95^\circ \\ \Theta_x &= 60.95^\circ\end{aligned}$$

$$R = 227.15 \text{ N}$$

Problem 02: Determine the resultant force of the force system as shown in figure 2(P: 02).

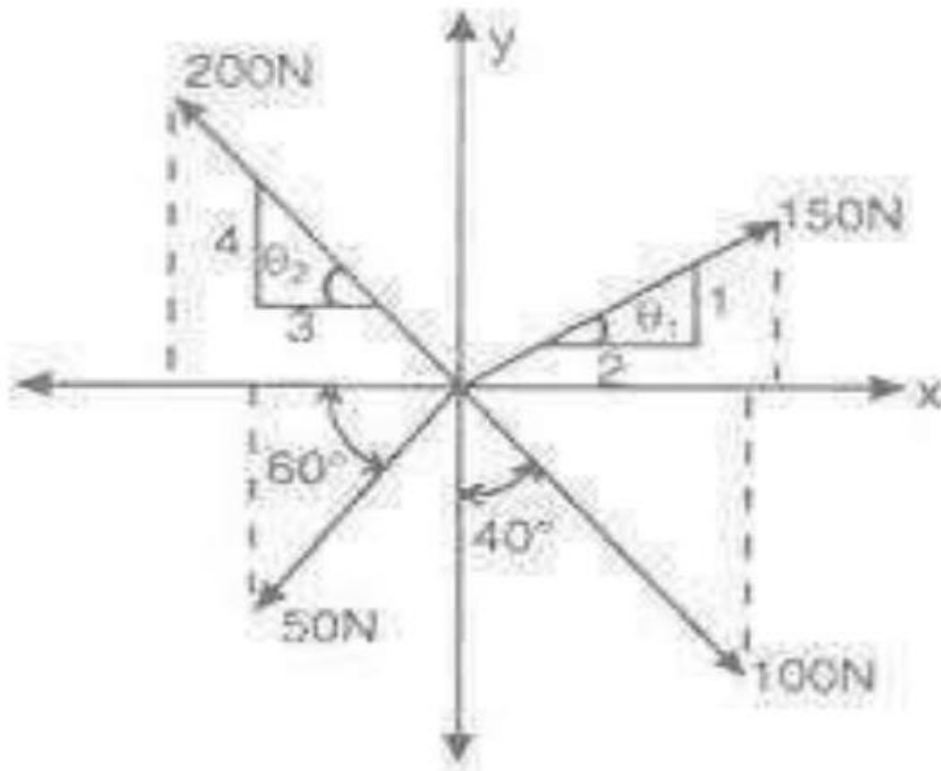

Figure (P: 02)

Solution:

$$\theta_1 = \tan^{-1} 1/2 = 26.57^\circ \quad \theta_2 = \tan^{-1} 4/3 = 53.13^\circ$$

$$\begin{aligned} \Sigma F_x &= R_x \\ &= 150\cos 26.57 - 200\cos 53.13 - 50\cos 60 + 100\cos 50 \\ &= 134.16 - 120.00 - 25.00 + 64.28 \\ &= 53.44 \text{ N} \end{aligned}$$

$$\begin{aligned} \Sigma F_y &= 0 \\ &= 150\sin 26.57 + 200\sin 53.13 - 50\sin 60 - 100\sin 50 \\ &= 67.09 + 160.00 - 43.30 - 76.60 \\ &= 107.19 \text{ N} \end{aligned}$$

$$R = \sqrt{53.44^2 + 107.19^2} = 119.77N$$

$$\Theta_x = \tan^{-1} 107.19/53.44 = 63.50^\circ$$

**R = 119.72 N**

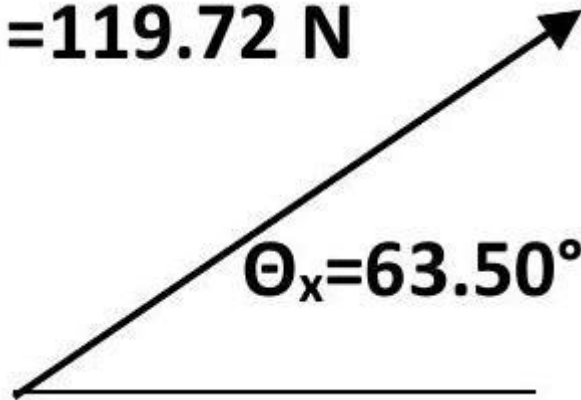

Problem 03: Determine the magnitude and direction of missing force  $P$  of the force system as shown in figure 3 (P: 03).

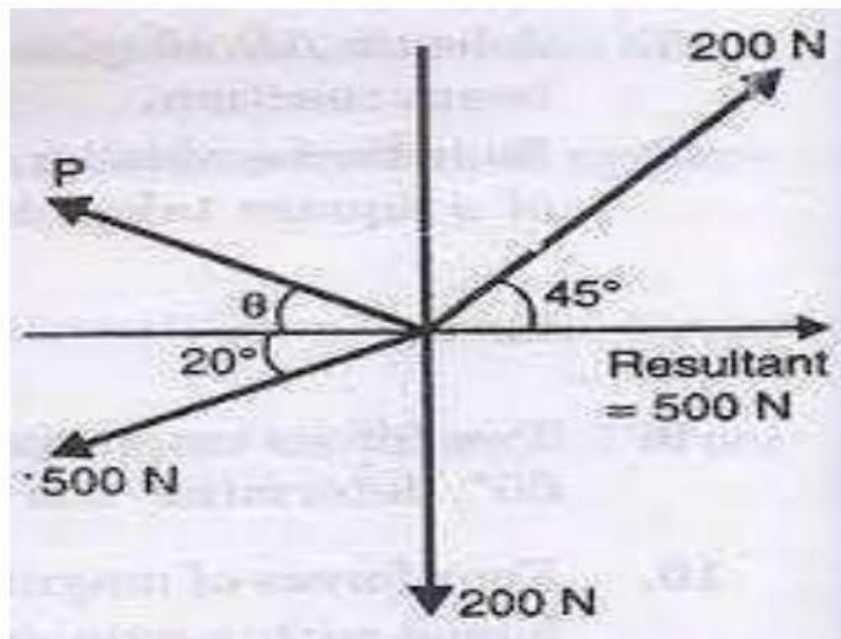

Figure (P: 03)

Solution:

$$\begin{aligned} \Sigma F_x &= R_x = 500N \\ &= 200\text{Cos}45 - 500\text{Cos}20 - P\text{Cos}\theta \end{aligned}$$

$$\begin{aligned}
 P\cos\theta &= -328.424 \\
 \Sigma F_y = R_y &= 0 \\
 &= 200\sin 45 - P\sin\theta - 500\sin 20 = 0
 \end{aligned}$$

$$P\sin\theta = -29.588$$

$$P\sin\theta / P\cos\theta = \tan\theta = -29.588 / -328.424 = 0.09$$

$$\begin{aligned}
 \theta &= 5.14^\circ \\
 P &= -329.754\text{N}
 \end{aligned}$$

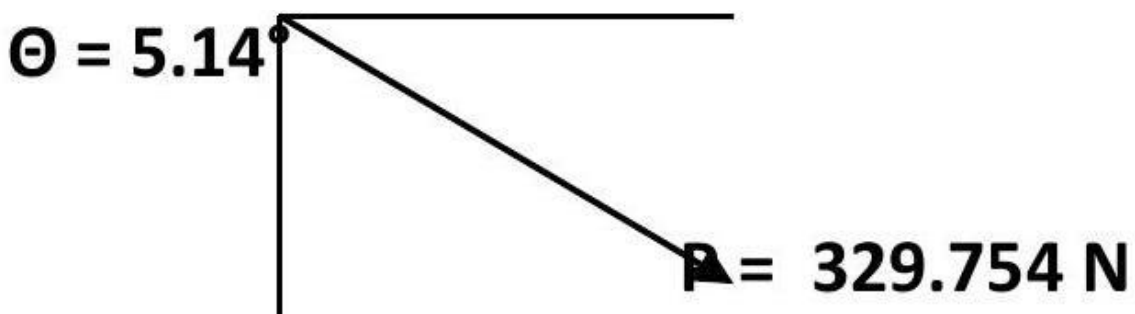

**Problems on Resultant of Coplanar non concurrent forces:**

Problem 04: Determine the resultant force of the force system as shown in figure ( **P: 04** ).

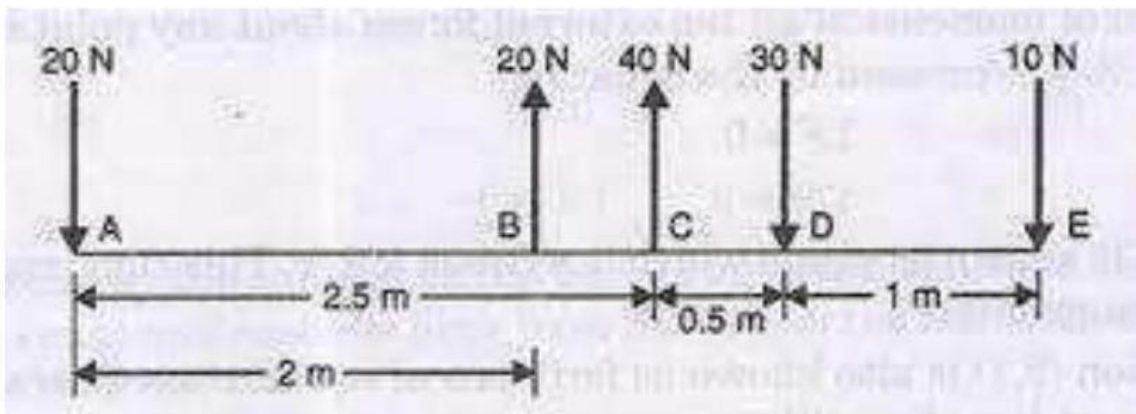

Figure (P: 04)

**Solution:**

$$\begin{aligned} \Sigma F_x &= R_x \\ &= 0 \\ \Sigma F_y &= R_y \\ &= -20 + 20 + 40 - 30 - 10 = 0 \\ R &= 0 \text{ N} \end{aligned}$$

Taking moment about the point A , we get  
 $20 * 0 - 20 * 2.0 - 40 * 2.5 + 30 * 3.0 + 10 * 4.0 = -10.0 \text{ N - m}$

The system does not have any resultant force i.e.  $r = 0.0$  but has a resultant moment of magnitude 10 N.m anticlockwise.

**Problem 05: Determine the resultant force of the force system as shown in figure ( P: 05 ).**

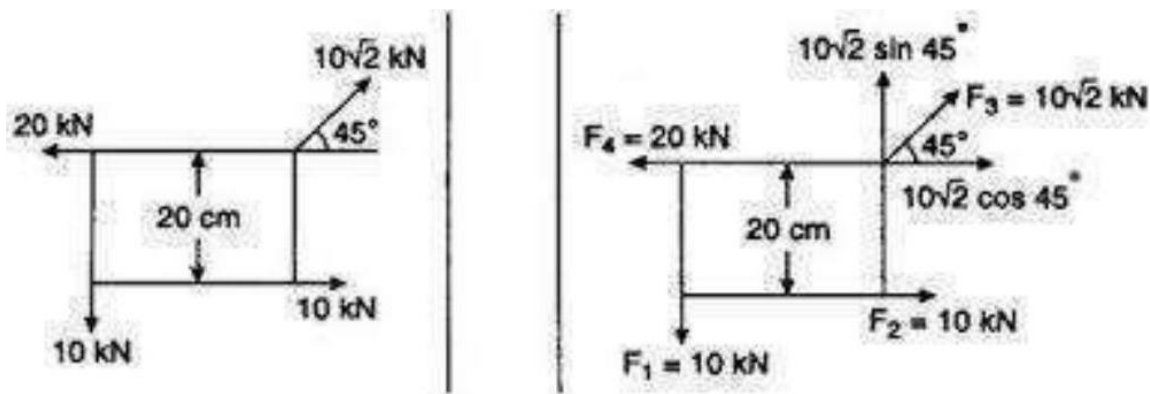

Figure (P: 05)

**Solution:**

$$\begin{aligned} \Sigma F_x &= R_x \\ &= -20 + 10 \sqrt{2} \cos 45 + 10 = 0.0 \\ \Sigma F_y &= R_y \\ &= 10 \sqrt{2} \sin 45 - 10 = 0.0 \\ R &= 0.0 \text{ N} \end{aligned}$$

Taking moment about the point where  $10 \sqrt{2}$  is acting, we get

$$- 10 * 0.2 + 10 * 0.3 = -1.0 \text{ N - m}$$

The system does not have any resultant force i.e. =  $\mathbf{R} = \mathbf{0.0}$  but has a resultant moment of magnitude  $1.0\text{N.m}$  anticlockwise.

**Problem 06:** Determine the resultant force of the force system as shown in figure ( **P: 06** ).

**Solution:**

$$\Theta_1 = \tan^{-1} 1/1 = 45.0^\circ \quad \Theta_2 = \tan^{-1} 3/4 = 36.86^\circ \quad \Theta_3 = \tan^{-1} 1/2 = 26.57^\circ$$

$$\begin{aligned} \Sigma F_x &= R_x \\ &= 2.0\cos 45 + 5\cos 36.86 - 1.5\cos 26.56 \\ &= 1.41 + 4 - 1.34 = 4.07\text{kN} \\ \Sigma F_y &= R_y \\ &= 2.0\sin 45 - 5\sin 36.86 - 1.5\sin 26.56 \\ &= 1.41 - 3.00 - 0.67 = -2.26\text{kN} \end{aligned}$$

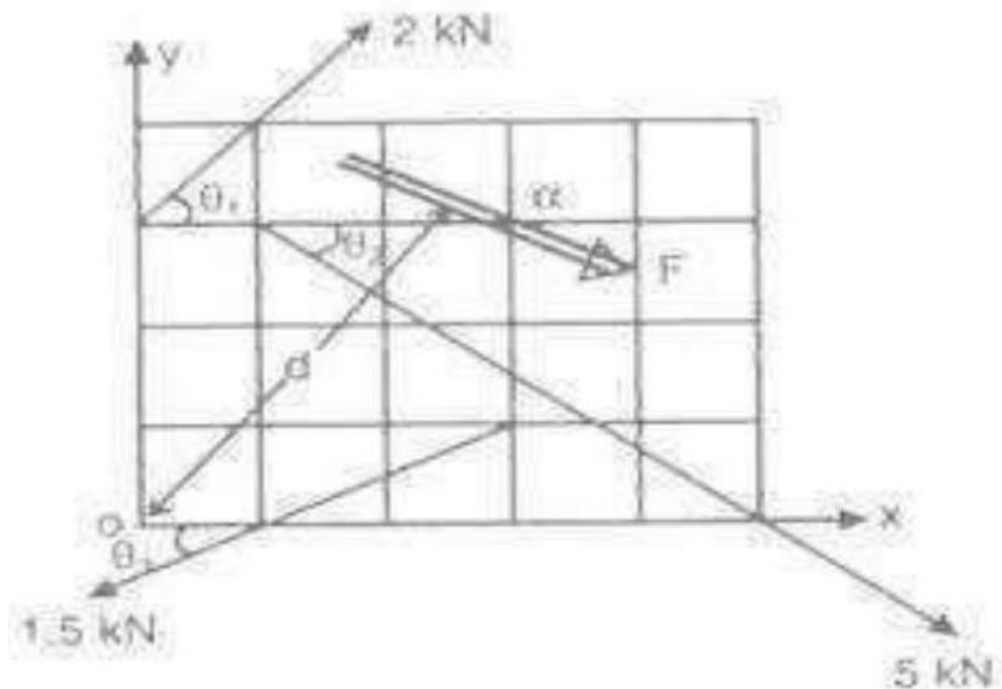

Figure (P: 06)

$$\begin{aligned} R &= \sqrt{4.07^2 + 2.26^2} = 4.66\text{kN} \\ \Theta_x &= \tan^{-1} 2.26/4.07 = 29.04^\circ \\ R &= 4.66\text{KN} \Theta_x = 29.04^\circ \end{aligned}$$

Assuming the grid size as 1.0 m × 1.0 m.

Taking moment about the point 0 , we get

$$-2\cos 45^\circ \cdot 3 + 5\cos 36.86^\circ \cdot 3 + 5\sin 36.86^\circ \cdot 1 - 1.5\cos 26.56^\circ \cdot 1 + 1.5\sin 26.56^\circ \cdot 3 = 11.42 \text{ kN.m.}$$

$$R_x \cdot y = 4.07 \cdot 7; y = 2.81 \text{ m.}$$

$$R_y \cdot x = 2.26 \cdot 7; x = 5.06 \text{ m.}$$

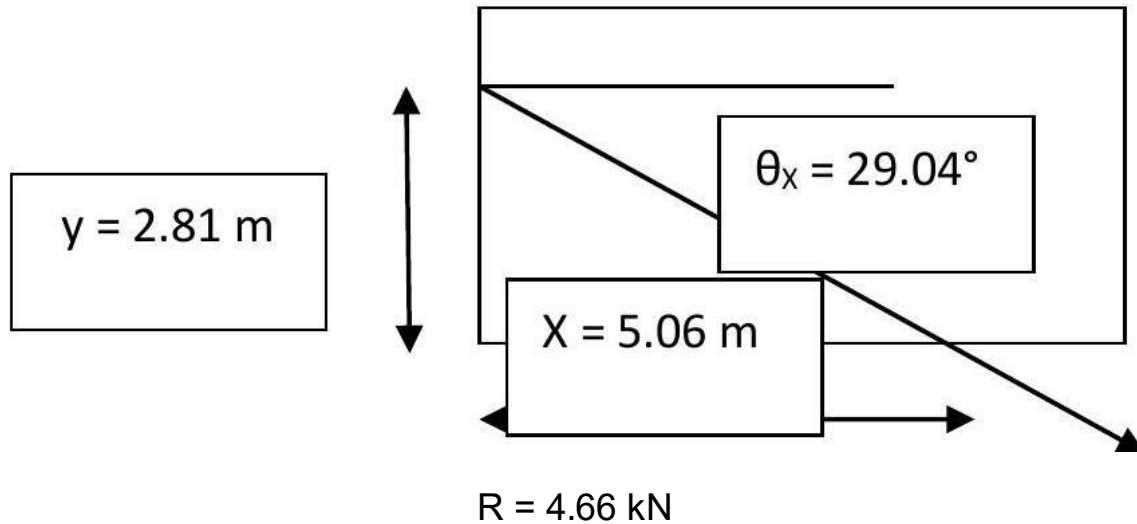

**Problem 07:** Determine the magnitude of force  $F$  and location of force  $F$  from a force system as shown in figure 7(P: 07).

**Solution:**

$$\begin{aligned} \Sigma F_x = R_x &= 0 \\ &= 0.0 \end{aligned}$$

$$\begin{aligned} \Sigma F_y = R_y &= 600 \text{ N} \\ &= 100 + F + 300 = 400 + F \\ F &= 200 \text{ N} \end{aligned}$$

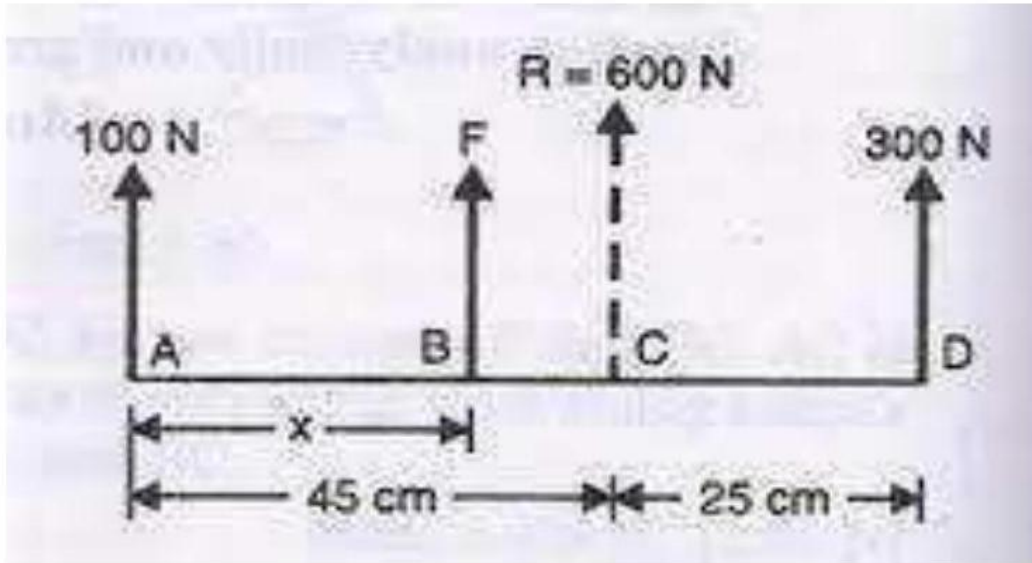

Figure ( P : 07)

Applying varignon's theorem with respect to point A, we get

$$F * x + 300 * 70 = R * 45 = 600 * 45 \text{ N. cm.}$$

$$X = 30.0 \text{ cm.}$$

**Problem 07: Determine the resultant force of the force system as shown in figure 7(P: 07). Diameter of circle is 2.0 m.**

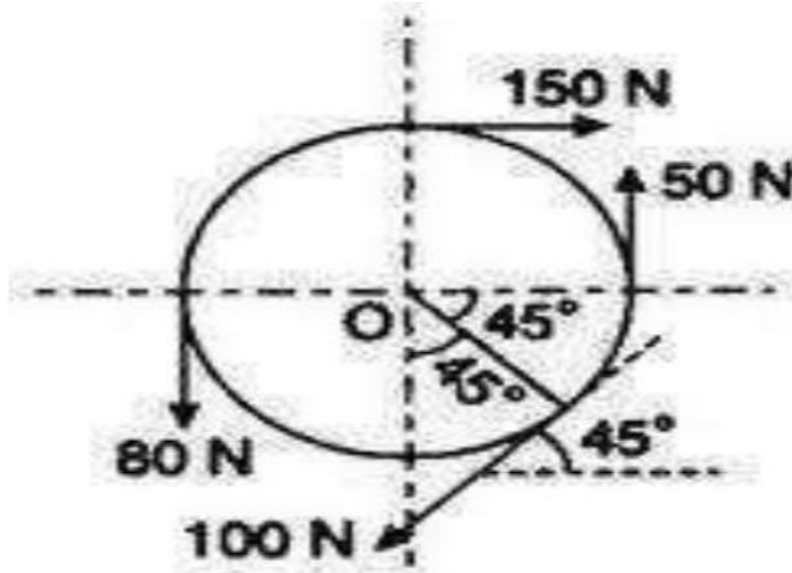

Figure (P: 07)

**Solution:**

$$\begin{aligned}\Sigma F_x &= R_x \\ &= 150 - 100\cos 45 = 150 - 106.07 = 43.93 \text{ N} \\ \Sigma F_y &= R_y \\ &= 50 - 80 - 100\sin 45 = 50 - 80 - 106.07 = -136.07 \text{ N}\end{aligned}$$

$$R = \sqrt{43.93^2 + 136.07^2} = 142.986 \text{ N}$$

$$\Theta_x = \tan^{-1} 136.07/43.93 = 72.11^\circ$$

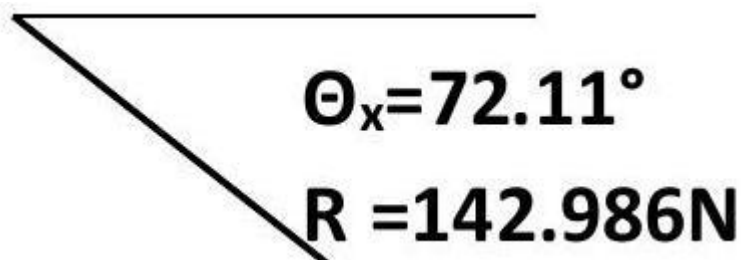

Applying Varignon's theorem with respect to point O , we get

$$150 * 1 - 50 * 1 + 100 * 1 - 80 * 1 = 120.0 \text{ Nm.}$$

$$R_x * y = 43.93 * y = 120.0; y = 2.73 \text{ m.}$$

$$R_y * x = 136.07 * x = 120.0; x = 0.88 \text{ m.}$$

**Problems on Equilibrium of Coplanar concurrent forces:**

Problem 08: Determine the directions of forces 20 kN and 30 kN with respect to the horizontal of the force system in equilibrium as shown in figure 08 (P: 08).

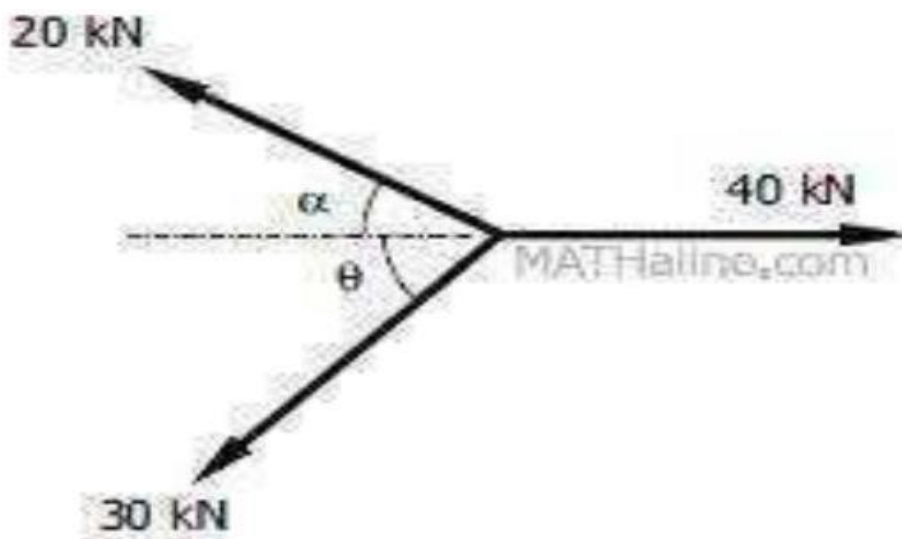

Figure (P: 08)

Solution:

$$\begin{aligned}\Sigma F_x &= 0 \\ &= 40 - 20\cos\alpha - 30\cos\theta = 0 \\ \cos\alpha &= 1.5\cos\theta - 2 \\ \Sigma F_y &= 0 \\ &= 20\sin\alpha - 30\sin\theta = 0 \\ \sin\alpha &= 1.5\sin\theta \\ \cos^2\alpha + \sin^2\alpha &= 1.5^2\cos^2\theta + 4 + 2*2*1.5*\cos\theta + 1.5^2\sin^2\theta \\ \text{Solving } \theta &= (28.96)^\circ \\ \alpha &= (46.57)^\circ\end{aligned}$$

**Problem 09: Determine the magnitudes of  $P$  and  $F$  forces of the force system in equilibrium as shown in figure 09 (P: 09).**

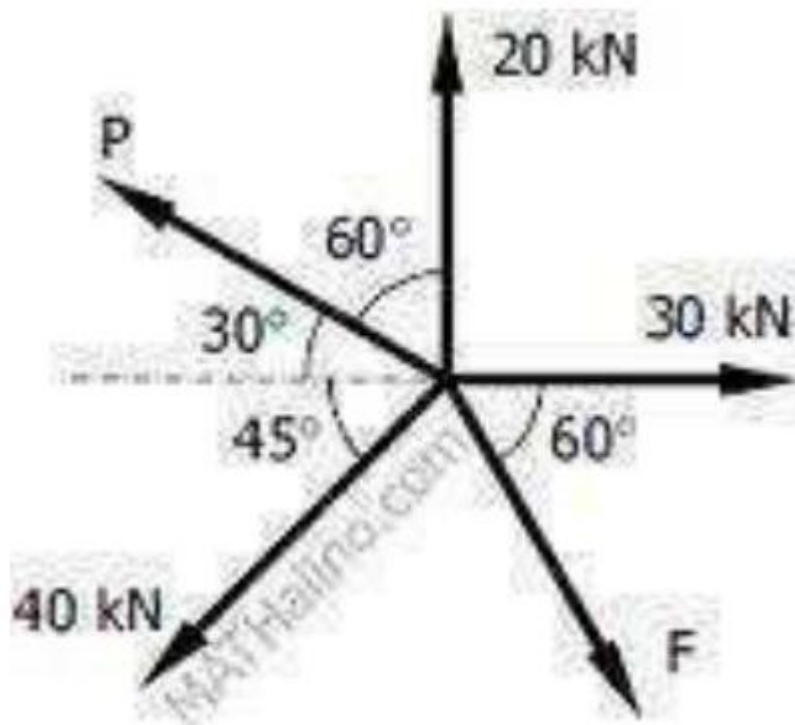

Figure ( P: 09 ).

**Solution:**

$$\begin{aligned}\Sigma F_x &= 0 \\ &= 30 - P\cos 30 - 40\cos 45 + F\cos 60 = 0 \\ \Sigma F_y &= 0 \\ &= 20 + P\sin 30 - 40\sin 45 - F\sin 60 = 0\end{aligned}$$

Solving  $F = 1.31\text{kN}$ .

$P = 21.33\text{kN}$ .

**Problems on strings:**

**Problem 10:** Determine the magnitudes of  $\theta$  with vertical for the string CD and tension in all segments of the string as shown in figure 10(P: 10).

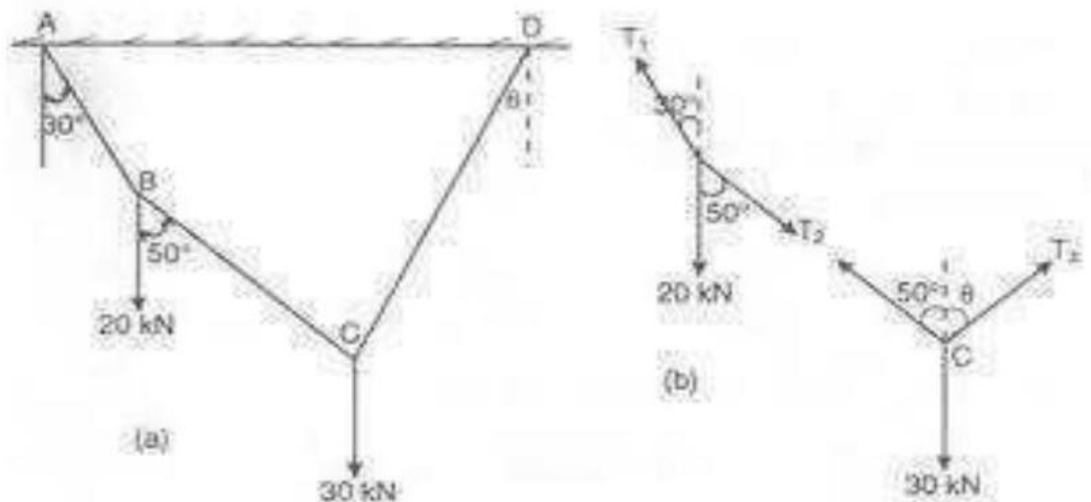

Figure ( P: 10 ).

**Solution:**

From the free body of joint B ,

$$T_{AB}/\sin 50 = 20/\sin 160 = T_{BC}/\sin 150$$

$$T_{AB} = 44.79 \text{ N.}$$

$$T_{BC} = 29.24 \text{ N.}$$

From the free body of joint C ,

$$29.24/\sin(180 - \theta) = 30/\sin(50 + \theta) = T_{CD}/\sin 130$$

$$29.24 \sin(50 + \theta) = 30\sin(180 - \theta)$$

$$22.4\cos \theta + 18.79\sin \theta = 30\cos \theta$$

$$18.79 \sin \theta = 7.6 \cos \theta$$

$$\theta = 22.02^\circ$$

$$T_{CD} = 59.74 \text{ N.}$$

**Problem 11:** Determine the magnitudes of tension in all segments of the string as shown in figure ( P : 11) when the weight of the block is 300 N .

**Solution:**

From the free body of joint,

$$T_1 / \sin 135 = (T_1 = 300) / \sin 135 = T_2 / \sin 90$$

$$T_2 = 424.26 \text{ N.}$$

$$T_3 = 300.00 \text{ N.}$$

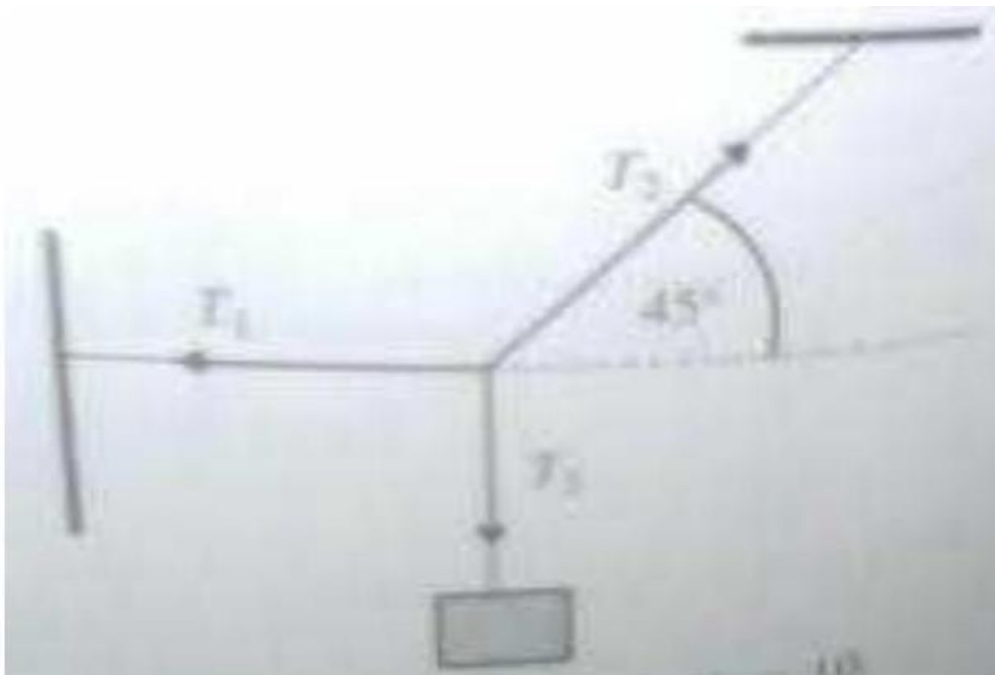

Figure ( P : 11).

**Problem 12:** Determine the magnitudes of tension in all segments of the string and the weight  $W$  for the string system as shown in figure 12 (P: 12).

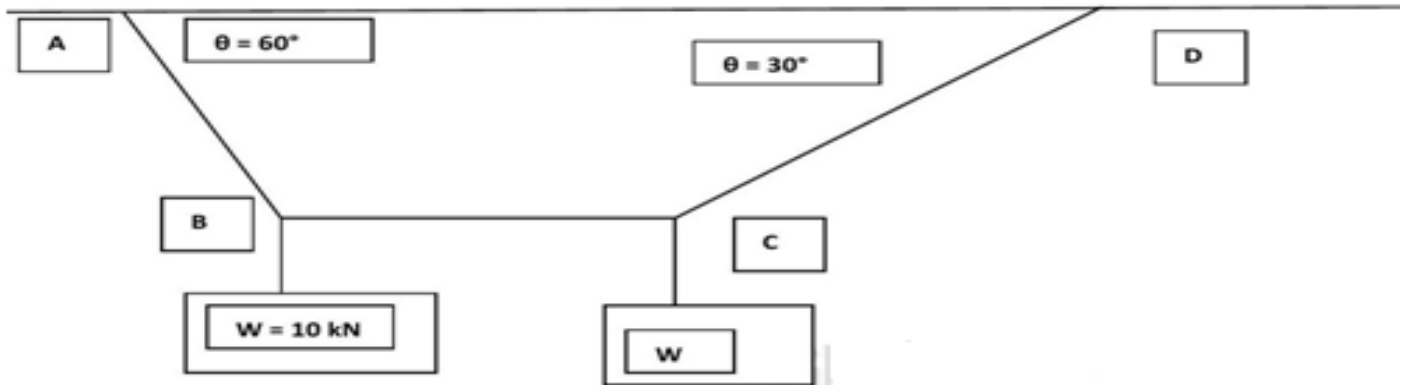

Figure 12 (P: 12).

**Solution:**

From the free body of joint B ,

$$T_{AB}/\sin 90^\circ = 10/\sin 150^\circ = T_{BC}/\sin 150^\circ$$

$$T_{CD} = 11.54 \text{ kN.}$$

$$T_{BC} = 5.77 \text{ kN.}$$

From the free body of joint C ,

$$T_{BC}/\sin 120^\circ = W/\sin 150^\circ = T_{CD}/\sin 90^\circ$$

$$W = 3.33 \text{ kN.}$$

$$T_{CD} = 6.67 \text{ kN.}$$

**Problems on Rollers/Cylinders:**

Note 01: When a circular surface come in contact with a plane surface, the reaction force at this contact point is perpendicular the plane surface as shown in figure. In Figure 17 (a) the plane surface is horizontal and the reaction  $R_A$  is perpendicular to plane (vertical) and in figure (b) the reaction  $R_A$  is also perpendicular the plane surface.

Note 02: When two circular surfaces come in contact with each other, the reaction force at this contact point is always along the line connecting their centre. In Figure

17 (d) the reaction  $R_{AB}$  at the point  $B$  is along  $O_1O_2$  which is the line connecting the centres of each cylinders.

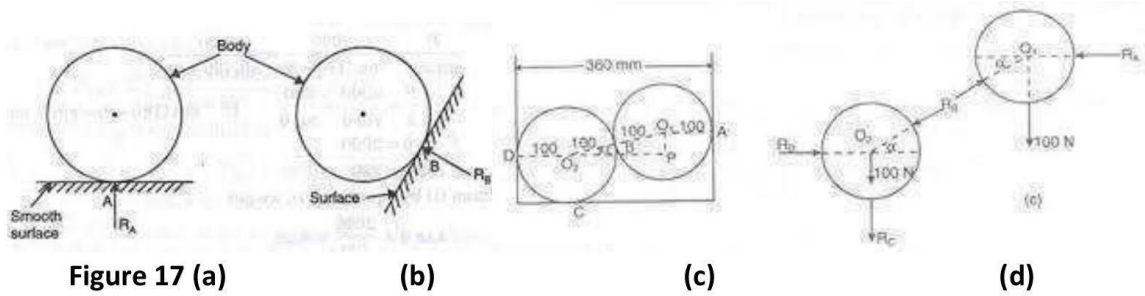

**Problem 13:** Determine the reactions at the contact surfaces  $A$  and  $B$  for the cylinder of weight  $1000\text{ N}$  resting as shown in figure 13(P: 13). In the problem  $\alpha = 70^\circ$  and  $\beta = 40^\circ$ .

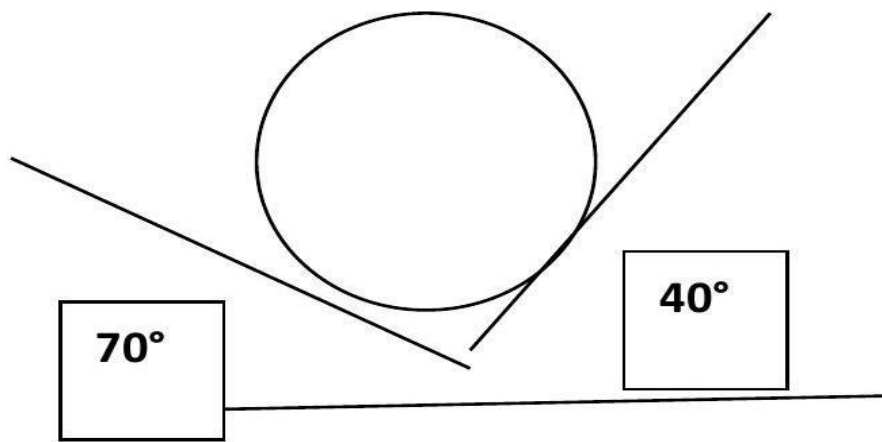
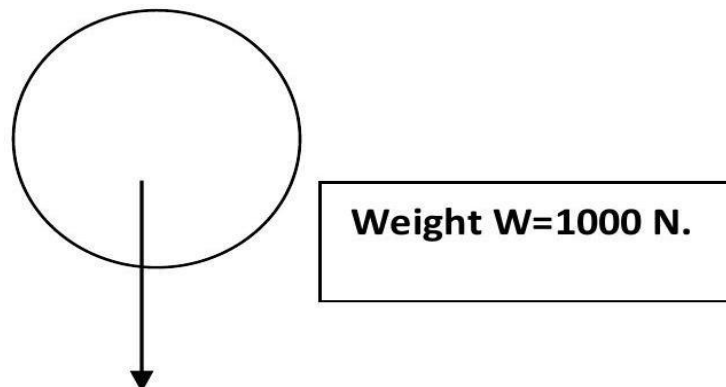
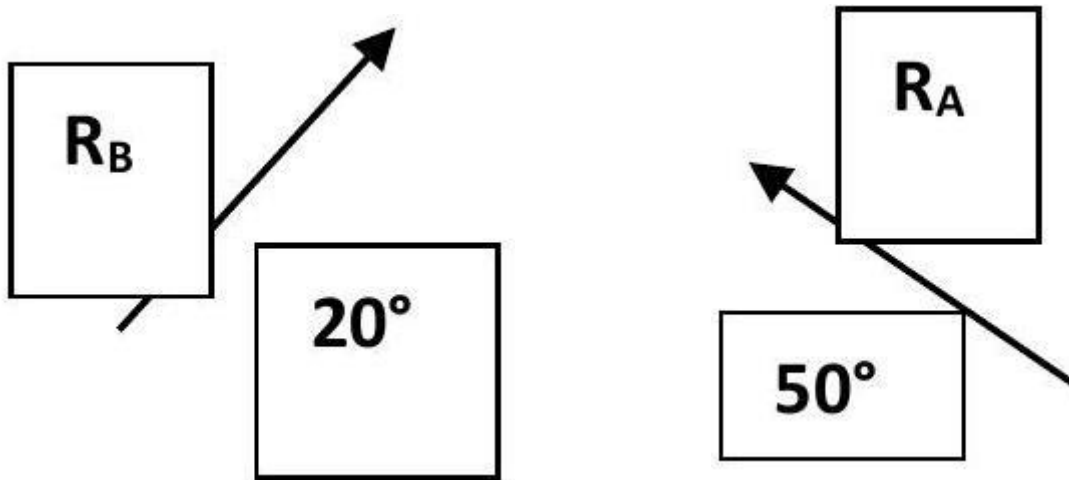

Figure 13 (P: 13).

The FBD of the cylinder are as given below





$$R_A/\sin(110) = R_B/\sin(140) = 1000/\sin(110)$$

$$R_A = 1000 \text{ N.}$$

$$R_B = 684.04 \text{ N}$$

**Problem 14:** Determine the reactions at the contact surfaces  $A, B, C$  and  $D$  for the cylinder of weight  $2.0 \text{ kN}$  and  $5.0 \text{ kN}$  resting as shown in figure 14 (P: 14).

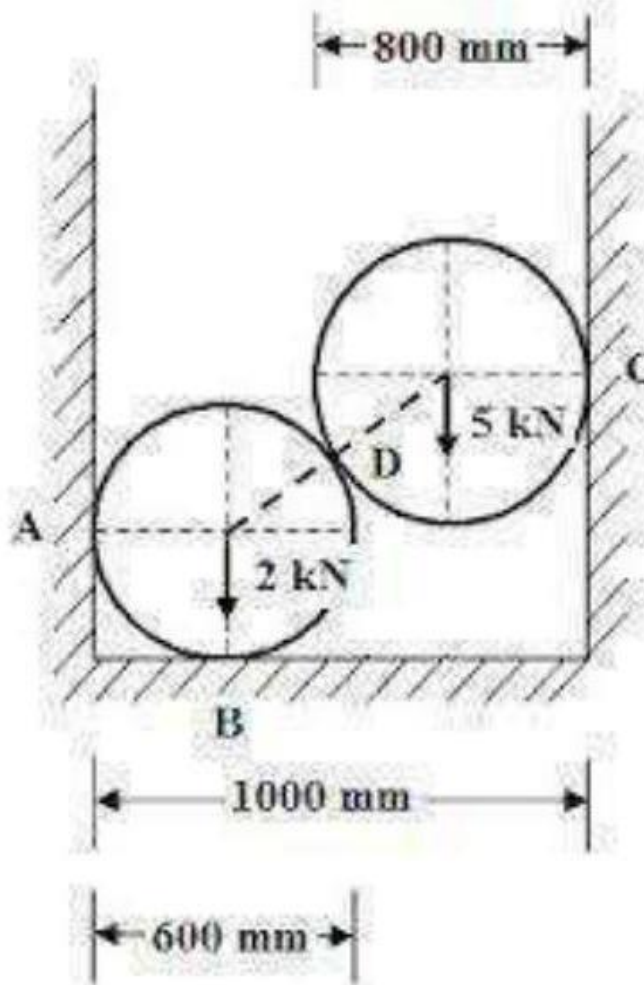

Figure 14 (P: 14).

### Solution:

The inclination of line connecting centre ( $\theta$ ) can be calculated as given below.

Length of line 0102 is given by Radius of 1 + Radius of 2 =  $400 + 400 = 800$  mm.

Length of horizontal line =  $1000 - 400 - 400 = 200.00$ mm.

$$\cos\theta = 200/800$$

$$\theta = 75.52^\circ$$

From the free body of top cylinder,

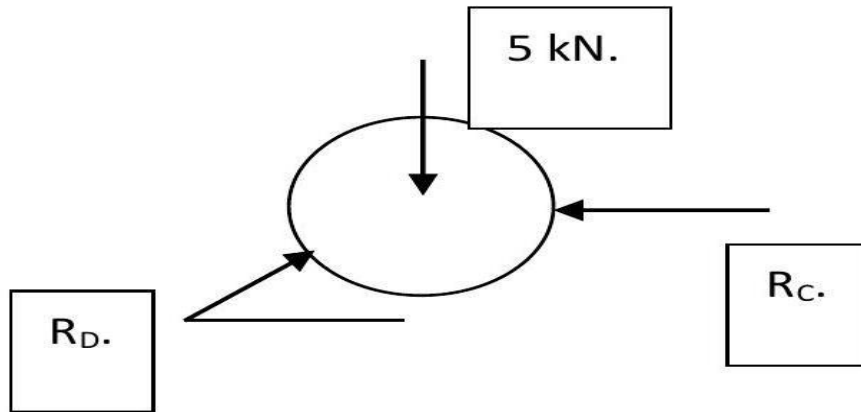

$$R_D / \sin 90 = 5 / \sin 107.48 = R_C / \sin 162.52$$

$$R_C = 1.57 \text{ kN.}$$

$$R_D = 5.24 \text{ kN.}$$

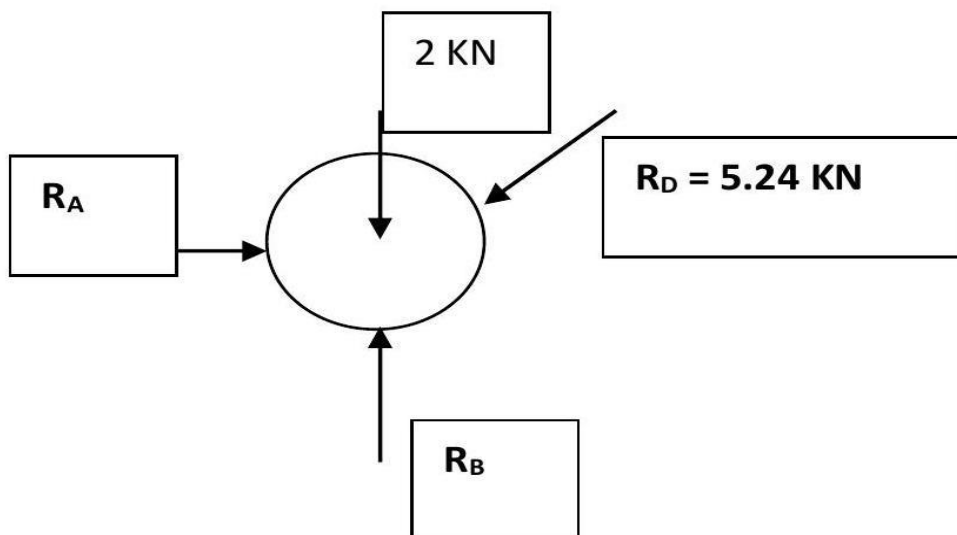

$$R_D - 2 - 5.24 \sin 72.52 = 0$$

$$R_D = 7.0 \text{ kN.}$$

$$R_A - 5.24 \cos 72.52 = 0$$

$$R_A = 1.57 \text{ kN.}$$

### Bow's notation:

Adding and subtracting two vectors (Graphical Method): When we add two vectors  $A$  and  $B$  by graphical method to get  $A + B$ , we take vector  $A$ , put the tail of  $B$  on the head of  $A$ . Then we draw a vector from the tail of  $A$  to the head of  $B$ . That vector represents the resultant  $R$  (Figure 4).

Let us try to understand that it is indeed meaningful to add two vectors like this. Imagine the following situations. Suppose when we hit a ball, we can give it velocity. Now imagine a ball is moving with velocity and you hit it an additional velocity. From experience you know that the ball will now start moving in a direction different from that of. This final direction is the direction of and the magnitude of velocity now is going to be given by the length of.

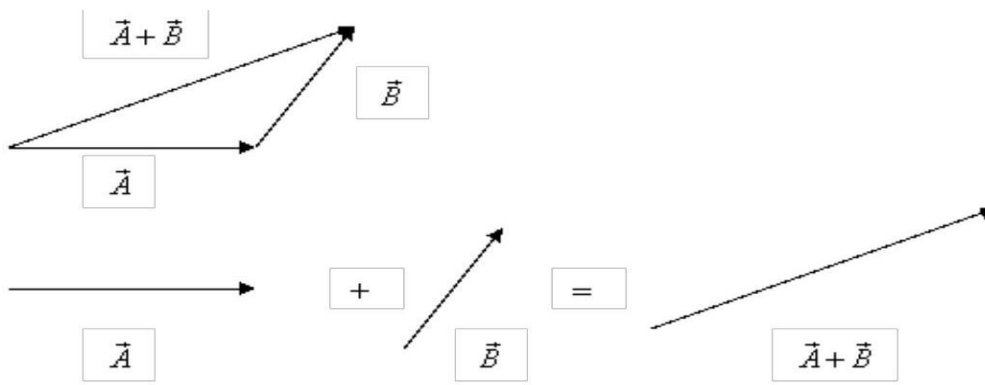

Figure: Adding two vectors.

## Trusses

Having set up the basics for studying equilibrium of bodies, we are now ready to discuss the trusses that are used in making stable load-bearing structures. The examples of these are the sides of the bridges or tall TV towers or towers that carry electricity wires. Schematic diagram of a structure on the side of a bridge is drawn in figure 18.

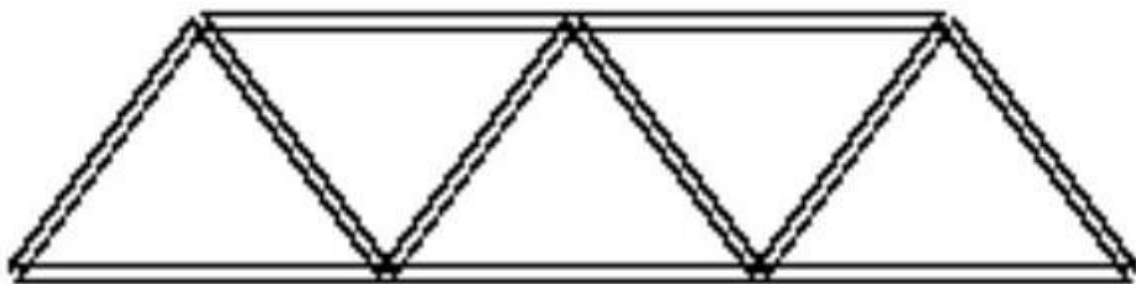

Figure 18: Truss

The structure shown in figure 18 is essentially a two-dimensional structure. This is known as a plane truss. On the other hand, a microwave or mobile phone tower is a three-dimensional structure. Thus there are two categories of trusses - Plane trusses like on the sides of a bridge and space trusses like the TV towers. In this

course, we will be concentrating on plane trusses in which the basic elements are stuck together in a plane.

Now we are ready to build a truss and analyze it. We are going to build it by adding more and more of triangles together. As you can see, when we add these triangles, the member of joints  $j$  and the number of members (rods)  $m$  are related as follows:

$$m = 2j - 3$$

This makes a truss statically determinate. This is easily understood as follows. First consider the entire truss as one system. If it is to be statically determinate, there should be only three unknown forces on it because for forces in a plane there are three equilibrium conditions. Fixing one of its ends a pin joint and putting the other one on a roller does that (roller also gives the additional advantage that it can help in adjusting any change in the length of a member due to deformations). If we wish to determine these external forces and the force in each member of the truss, the total number of unknowns becomes  $m + 3$ . We solve for these unknowns by writing equilibrium conditions for each pin; there will be  $2j$  such equations. For the system to be determinate we should have  $m + 3 = 2j$ , which is the condition given above. If we add any more members, these are redundant. On the other hand, less number of members will make the truss unstable and it will collapse when loaded. This will happen because the truss will not be able to provide the required number of forces for all equilibrium conditions to be satisfied. Statically determinate trusses are known as simple trusses.

We now wish to obtain the forces generated in various arms of a truss when it is loaded externally. This is done under the following assumptions:

1. If the middle line of the members of a truss meet at a point that point is taken as a pin joint. This is a very good assumption because as we have seen earlier while introducing a truss (triangle with pin joint), the load is transferred on to other member of the trusses so that forces remain essentially collinear with the member.
2. All external loads are applied on pin connections.
3. All members' weight is equally divided on connecting pins.

There are two methods of determining forces in the members of a truss - Method of joints and method of sections.

Method of joints: In method of joints, we look at the equilibrium of the pin at the joints. Since the forces are concurrent at the pin, there is no moment equation and

only two equations for equilibrium viz.  $\sum F_x = 0$  and  $\sum F_y = 0$ . Therefore we start our analysis at a point where one known load and at most two unknown forces are there. The weight of each member is divided into two halves and that is supported by each pin. The method of joints consists of satisfying the equilibrium equations for forces acting on each joint.

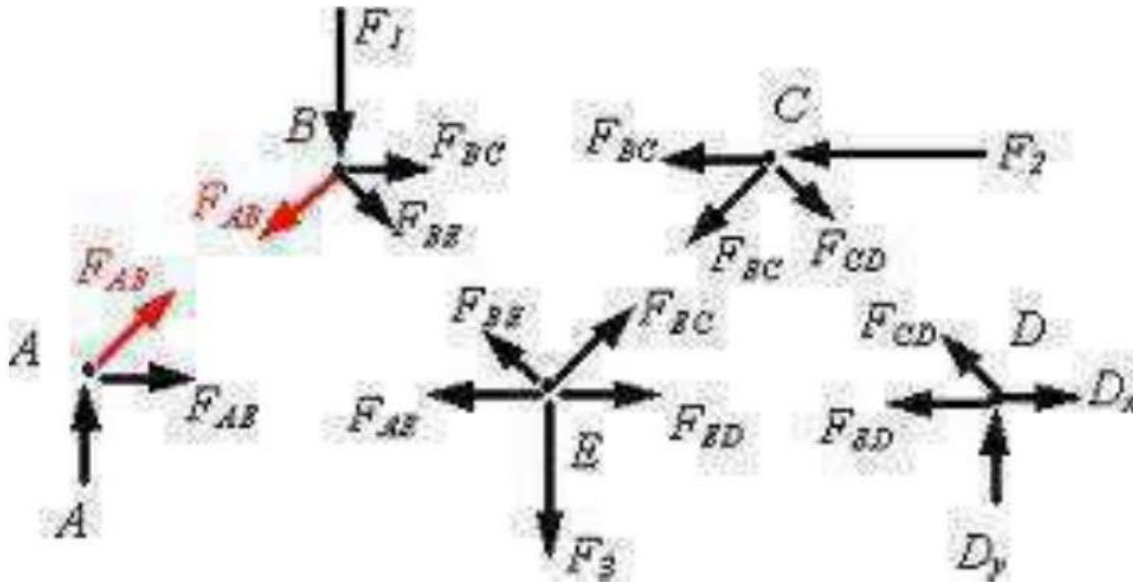

Figure 19 (a): FBD of joints in method of joints.



Figure 19 (b): Tension member of truss.



Figure 19 (c): Compression member of truss.

Procedure for analysis - the following is a procedure for analyzing a truss using the method of joints:

1. If possible, determine the support reactions

2. Draw the free body diagram for each joint. In general, assume all the force member reactions are tension (this is not a rule, however, it is helpful in keeping track of tension and compression members).
3. Write the equations of equilibrium for each joint,
 
$$\Sigma F_x = 0 \text{ and } \Sigma F_y = 0$$
4. If possible, begin solving the equilibrium equations at a joint where only two unknown reactions exist. Work your way from joint to joint, selecting the new joint using the criterion of two unknown reactions.
5. Solve the joint equations of equilibrium simultaneously, typically using a computer or an advanced calculator.

**Method of sections:** As the name suggests in method of sections we make sections through a truss and then calculate the force in the members of the truss though which the cut is made. For example, if I take the problem we just solved in the method of joints and make a section  $S_1, S_2$  (see figure 9), we will be able to determine the forces in members BC, BE and FE by considering the equilibrium of the portion to the left or the right of the section.

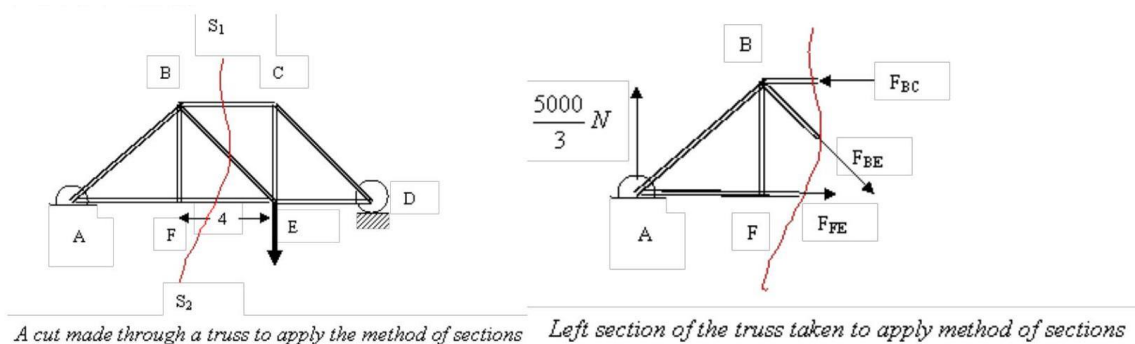

Figure 20: method of sections.

Since this entire section is in equilibrium,  $\Sigma F_x = 0$ ,  $\Sigma F_y = 0$  and  $\Sigma M = 0$ . Notice that we are now using all three equations for equilibrium since the forces in individual members are not concurrent. The direction of force in each member, one can pretty much guess by inspection. Thus the force in the section of members BE must be pointing down because there is no other member that can give a downward force to counterbalance  $5000/3N$  reaction at A. This clearly tells us that  $F_{BE}$  is tensile. Similarly, to counter the torque about B generated by  $5000/3N$  force at A, the force on FE should also be from F to E. Thus this force is also tensile. If we next consider the balance of torque about A,  $5000/3 N$  and  $F_{FE}$  do not give any torque about A. So to counter torque generated by  $F_{BE}$ , the force on BC must act towards B,

thereby making the force compressive.

After this illustration let me put down the steps that are taken to solve for forces in members of a truss by method of sections:

1. Make a cut to divide the truss into section, passing the cut through members where the force is needed.
2. Make the cut through three member of a truss because with three equilibrium equations viz  $\sum F_x = 0$ ,  $\sum F_y = 0$  and  $\sum M = 0$ . we can solve for a maximum of three forces.
3. Apply equilibrium conditions and solve for the desired forces.

In applying method of sections, ingenuity lies in making a proper. The method after a way of directly calculating desired force circumventing the hard work involved in applying the method of joints where one must solve for each joint.



If you have any queries please visit- <https://studywithakash.in/>

Gmail – [studywithakash311@gmail.com](mailto:studywithakash311@gmail.com)

+918871317984

**THANK YOU**