

UNIT- 3 FLUID

Introduction [RGPV Jan08, June09, April 09]

Fluid

A fluid is a substance that may flow. That is, the particles making up the fluid continuously change their positions relative to one another. Fluids do not offer any lasting resistance to the displacement of one layer over another when a shear force is applied. This means that if a fluid is at rest, then no shear forces can exist in it, which is different from solids; solids can resist shear forces while at rest. To summarize, if a shear force is applied to a fluid it will cause flow.

Fluid properties

Density

Density is the ratio of the mass of a given amount of the substance to the volume it occupies. Mean density is defined as the ratio of a given amount of a substance to the volume that this amount occupies. The density is said to be uniform if the mean density in all parts of the substance is the same.

Pressure

To define pressure, consider some imaginary surface of area A at an arbitrary part of a fluid. This surface must experience forces, say of magnitude F , due to a very large number of molecular collisions from the fluid adjoining it. Pressure, which is a scalar quantity, is defined as the ratio of the force and the area, that is F/A .

Dimensional Formula is: [ML⁻¹T⁻²]

Viscosity

Viscosity can be thought of as the internal “stickiness” of a fluid. It is one of the properties that controls the amount of fluid that can be transported in a pipeline during a specific period of time. It accounts for the energy losses associated with the transport of fluids in ducts, channels and pipes. Further, viscosity plays an important role in the generation of turbulence. Needless to say, viscosity is an extremely important fluid property in our study of fluid flows.

All real fluids resist any force tending to cause one layer to move over another, but the resistance occurs only when the movement is taking place. On removal of the external force, flow subsides because of the resisting forces. But unlike solids that may return to their original position, the fluid particles stay in the position they have reached and have no tendency to return to their original positions. The resistance to the movement of one layer of fluid over an adjoining one is due to the viscosity of the fluid.

From experiments with various fluids, Sir Isaac Newton postulated that for the straight and parallel motion of a given fluid, the tangential stress between two adjoining fluid layers is proportional to the velocity gradient in a direction perpendicular to the layers. That is:

$$\tau \propto \mu \, du/dy$$

Where μ a constant for a particular fluid at a particular temperature. The coefficient of proportionality is the **absolute viscosity** (sometimes referred to as the coefficient of viscosity). Note that μ is a scalar quantity, while the other terms are vector quantities. Note also that the surface over which the stress acts is perpendicular to the velocity gradient. If the velocity u increases with y , then the velocity gradient is positive and so τ also must be positive. So the positive sense of the shear stress is defined as being the same as the positive sense of the velocity.

Kinematic Viscosity:

The **kinematic viscosity**, ν , is defined as the ratio of absolute viscosity to density:

$$\nu = \mu / \rho$$

Dimensional formula: [L-2T-1]

The interest in expressing this ratio will become clearer in discussion on Reynolds number and its use in turbulent and laminar flows where the ratio of viscous forces, (which is proportional to μ), to the inertial forces (which is proportional to ρ) is involved.

Types of fluids

Fluids are classified as under:

1. Ideal fluid
2. Newtonian fluid

3. Non-Newtonian fluid
4. Real fluid
5. Ideal plastics

Ideal fluid- A fluid which is non-viscous in nature is known as an ideal fluid. It is an imaginary fluid. $\mu=0$. It is shown by line f' (Fig.) on shear stress-velocity gradient graph.

Newtonian Fluid- A fluid in which shear stress is proportional to the velocity gradient is known as Newtonian fluid. Fluid, represented by curve a and a₁, are Newtonian fluids. Fluid represented by curve a₁ is more viscous than the fluid represented by curve a₂ (Fig.).

For Newtonian fluid $\tau = \mu \frac{dU}{dY}$

Non-Newtonian Fluid A fluid in which shear stress is not proportional to the velocity gradient is known as Non-Newtonian fluid, e.g., thick lubricating oil.

For Newtonian fluid $\tau = \mu \left(\frac{dU}{dY} \right)^n$

For non-Newtonian fluids n is less than unity then it is called pseudo-plastics e.g., milk, blood, liquid cement: while fluids in which n is greater than unity are called dilatants e.g... Concentrated solution of sugar. Aqueous solution of rice starch.

Real Fluid- A fluid which possesses viscosity is known as real fluid, all the fluids in actual practice are real fluid.

Ideal Plastic fluid- A fluid in which shear stress is more than the yield value and shear stress is proportional to velocity gradient is known as ideal plastic as represented by curve, d

$$\tau = \mu du/dy + \text{constant}$$

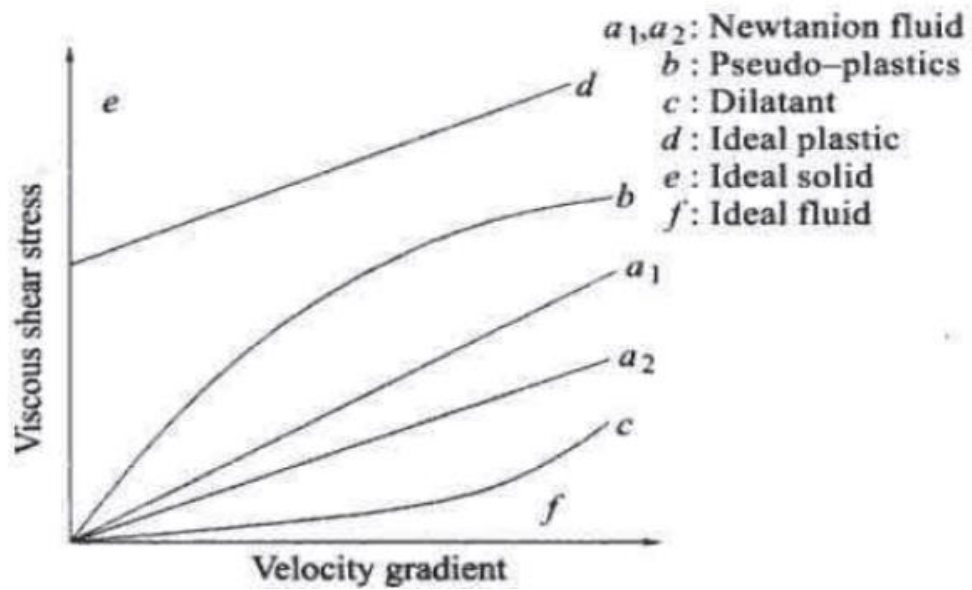

Force on the plate = 1.5 N

Area of plate = 1 N/m^2

$$\tau = 1.5 \text{ N/m}^2$$

Distance between the two plates $dy = 0.25 \text{ mm} = 0.25 \times 10^{-3} \text{ m}$.

Relative velocity of the upper plate w.r.t. lower plate $du = 50 \text{ cm/sec} = 0.5 \text{ m/s}$.

Using the relation $\tau = \mu \frac{du}{dy}$

$$\begin{aligned}
 \mu &= \tau / \frac{du}{dy} \\
 &= 1.5 / (0.5 / 0.25 \times 10^{-3}) \\
 &= 7.5 \times 10^{-4} \text{ N-s/m}^2 \\
 &= 7.5 \times 10^{-3} \text{ poise [10 poise = 1 Ns/m}^2]
 \end{aligned}$$

Ans. Viscosity 7.5×10^{-3}

poise

Question 2 Two square parallel plates of side 0.6m are placed at a distance of 12.5 mm apart. The lower plate is fixed while the upper plate is moving with a velocity of 2.5m/s. Determine the dynamic viscosity of oil in poise, if a force of 98 N is required to maintain the mentioned speed.

Solution:

Given

Force =F=98 N

The velocity of Lower fixed plate = $u_1 = 0$ m/s

The velocity of upper moving plate = $u_2 = 2.5$ m/s then $du = u_2 - u_1 = 2.5$ m/s

area of the square plate = $A = 0.6 \times 0.6 = 0.36 \text{ m}^2$

The distance between the two plates = $dy = 12.5 \text{ mm} = 0.0125 \text{ m} = 12.5 \times 10^{-3} \text{ m}$

Find(μ)= ?

Substituting the values in the above equation

Force required to maintain the mentioned speed = $F = \tau \times A$

$\tau = F/A = 98/0.36 = 272.22 \text{ N/m}^2$

Substituting the values

$$\tau = \mu \frac{du}{dy}$$

$$272.22 = \mu(2.5/0.0125)$$

$$\mu = 1.36 \text{ Ns/m}^2 \text{ or } 13.6 \text{ poise } \textbf{Answer}$$

Question 3 The clearance between the shaft of diameter 10 cm and its journal bearing is 1.5 mm is filled with lubricating oil of viscosity 10 poise. Determine (i) the intensity of shear stress of the oil if the shaft rotates at 150 revolutions per minute. (ii) Calculate the power lost in the bearing if the length of the sleeve is 12cm.

Solution:

Given

$\mu = 10$ poise = $10/10 = 1 \text{ Ns/m}^2$

Diameter of shaft $D = 10 \text{ cm} = 0.1 \text{ m}$

Distance between shaft and journal bearing,

$$dy = 1.5 \text{ mm} = 1.5 \times 10^{-3} \text{ m}$$

Speed of shaft $N = 300$ rpm

Tangential speed of shaft is given by

$$u = (\pi DN)/60 = (\pi \times 0.1 \times 300)/60 = 1.57 \text{ m/s}$$

Using Equation- $\tau = \mu du/dy$

where , $du =$ change of peripheral velocity of the shaft relative to the journal bearing
 $= u - 0 = u$

$$\tau = (1.57)/(1 \times 1.5 \times 10^{-3}) = 1047.2 \text{ N/m}^2. \textbf{Answer}$$

Length of the sleeve = $L = 0.12 \text{ m}$

Shear force on the shaft = shear stress \times curve surface area of the sleeve

$$F = \tau \times \pi \times D \times L = 1047.2 \times \pi \times 0.1 \times 0.12 = 39.5 \text{ N}$$

$$\text{Torque on the shaft} = F \times D/2 = 39.5 \times 0.1/2 = 1.97 \text{ Nm}$$

$$\text{Power lost} = 2\pi NT/60 = 2\pi \times 300 \times 1.97/60 = 61.9 \text{ W} \quad \text{Answer}$$

Question 2 A vertical cylinder of 15 cm diameter rotates concentrically inside another cylinder of diameter 15.1 cm. the space between the cylinder is filled with a lubricating oil whose viscosity is not known. If the torque of 15 Nm is required to rotate the inner cylinder at 120 rpm calculate the viscosity of the oil. Assume the height of both the cylinder to be 25 cm.

Solution:

Given

Diameter of inner cylinder = $D = 15 \text{ cm} = 0.15 \text{ m}$

Diameter of outer cylinder = $D_2 = 15.1 \text{ cm} = 0.151 \text{ m}$

Height of the cylinder = $L = 25 \text{ cm} = 0.25 \text{ m}$

Torque = $T = 15 \text{ Nm}$

Speed of the inner cylinder = $N = 120 \text{ rpm}$

Let μ be the viscosity of the oil

Tangential velocity of the rotating cylinder = $u = \pi DN/60 = \pi \times 0.15 \times 120/60 = 0.942 \text{ m/s}$

Curved surface area of the inner cylinder = $A = \pi DL = \pi \times 0.15 \times 0.25 = 0.1178 \text{ m}^2$

The distance/clearance between the inner and outer cylinder = $dy = (0.151 - 0.150)/2 = 0.0005 \text{ m}$

$$du = u - 0 = u = 0.942 \text{ m/s}$$

shear force = $F = \text{shear stress} \times \text{curved surface area} = \tau \times A$

$$\tau = \mu \frac{du}{dy}$$

$$\text{Torque} = T = F \times D/2$$

Substituting the values

$$15 = \mu \times (0.942/0.0005) \times 0.1178 \times 0.15/2$$

$$\mu = 0.901 \text{ N-s/m}^2 \text{ or } 9.01 \text{ poise.} \quad \text{Answer}$$

Pascal law

It states that the intensity of pressure at any point in a static fluid in all direction is equal.

Consider a wedge shape element of size di , dv , $d.c$ respectively in a fluid at rest as shown in Fig. Let P_x , P_y , P_θ be the pressure acting normal to the surfaces OACD, OABE, BEDC respectively. The element is also acted on by gravitational body force acting vertically in the downward direction.

If width d of the wedge element perpendicular to paper is equal to unity, i.e., $dz = 1$

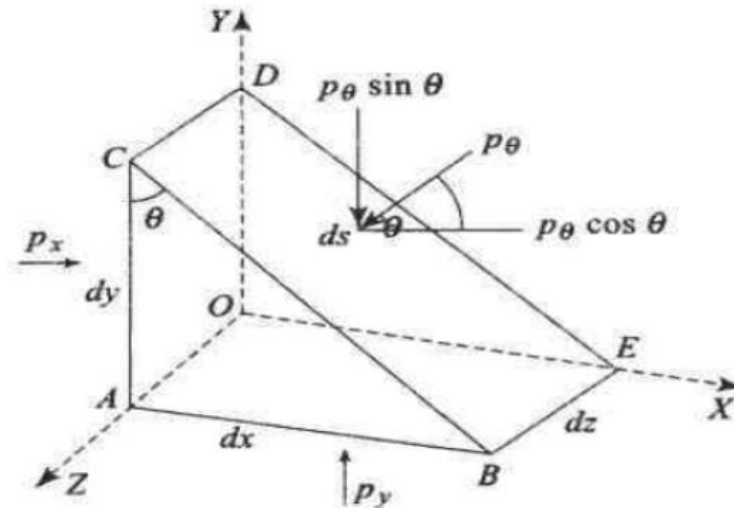

Forces on a Wedge Shape Element

Then,

- force acting on the face OACD = $P_x (dy. 1)$
- force acting on the face OABE = $P_y (dx. 1)$
- force acting on the face BEDC = $P_\theta (ds. 1)$

The weight of the fluid element = (Volume of an element) (density of fluid).(acceleration due to gravity)

$$= dv.p.g$$

$$= 1/2 (AB.AC).l.p.g$$

As the fluid element is in equilibrium, the sum of forces in horizontal direction and in vertical direction must be zero.

Resolving the forces in X-direction

$$P_x (dy. 1) - P_\theta (ds. 1) \cos\theta = 0$$

$$P_x (dy. 1) - P_\theta (dy. 1) = 0 \quad [ds \cos\theta = dy]$$

$$\mathbf{P_x = P_\theta \dots\dots\dots(A)}$$

Resolving the forces in Y-direction

$$P_y (dx. 1) - P_\theta (ds. 1)\sin\theta - 1/2 (dx.dy.1).p.g = 0$$

Let the size of the element approach smaller, and then the gravitational force which is the product of dx and dy can be neglected.

$$P_y (dx. 1) - P_\theta (ds. 1)\sin\theta = 0$$

$$P_y (dx. 1) - P_\theta(dx. 1) = 0 \quad [ds \sin\theta = dx]$$

$$\mathbf{P_y = P_\theta \dots\dots\dots(B)}$$

From Eqs A & B

$$\mathbf{P_x = P_y = P_\theta}$$

The above relation shows that the pressure at any point x, y, z in a static fluid is independent of θ , it follows that the pressure in all the directions in a static fluid is same.

Pressure variation in a static fluid

Consider an imaginary infinitesimal cylindrical element in a fluid at rest at a distance y from the top surface of the fluid as shown in Fig.

Let dA be the cross-sectional area, dy the height of the cylindrical element in the fluid.

The pressure forces acting on the cylindrical element are:

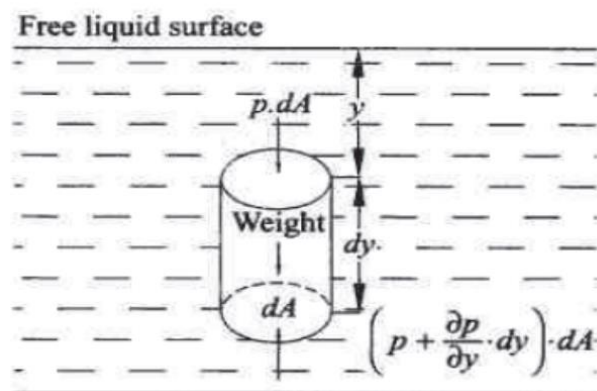

1. pressure force on the top surface of the cylindrical element $P \cdot dA$ acting in vertically down- Element ward direction.

2. pressure force at the bottom surface of the cylindrical element $(p + (\partial p/\partial y) dy) \cdot dA$ acting in vertically upward direction.

3. weight of the fluid element acting in the downward direction, $dA \cdot dy \cdot \rho g$,

where ρ is the density of the fluid and g is the acceleration due to gravity.

4. Summation of pressure forces on the curved surface of the cylindrical fluid element is equal to zero.

As the fluid element is in equilibrium, the sum of downward forces must be equal to the sum of upward forces acting on it. Therefore,

$$p \cdot dA - (p + (\partial p/\partial y) dy) \cdot dA + dA \cdot dy \cdot \rho g = 0$$

$$\partial p/\partial y + \rho g = 0$$

$$\partial p/\partial y = -\rho g = -w \text{ (specific weight of the fluid)}$$

By integrating the above equation

$$\int dp = \int -\rho g dy$$

$$p = -\rho g y$$

where. p is the pressure intensity at a point, y distance from the free surface of the fluid. Thus, the pressure will be constant everywhere over the same level of surface in a continuous body of a static fluid. It also indicates that in a static fluid, pressure increases as the depth increases.

Bernoulli's Equation [RGPV Dec 08,june08,09,april 09,sep 09]

In a streamline, steady flow of an ideal and incompressible fluid the sum of the pressure energy, kinetic energy and potential energy at any point in the fluid flow is constant.

(Streamline is defined as an imaginary line drawn in a flow fields such that tangent to it at any point gives the direction of velocity vector at that point, at an instant. Mathematically it can be expressed as

$$P/\rho + V^2/2 + Zg = \text{constant.}$$

Or $P/\rho g + V^2/2g + Z = \text{constant.}$

where $P/\rho g$ is pressure head

$V^2/2g$ velocity head

z is potential head

ρ density of fluid Kg/m^3

P pressure intensity at a point in the fluid N/m^2

V velocity of the fluid particle at that point m/s

Consider a cylindrical element along a streamline in a fluid flow as shown in the fig.

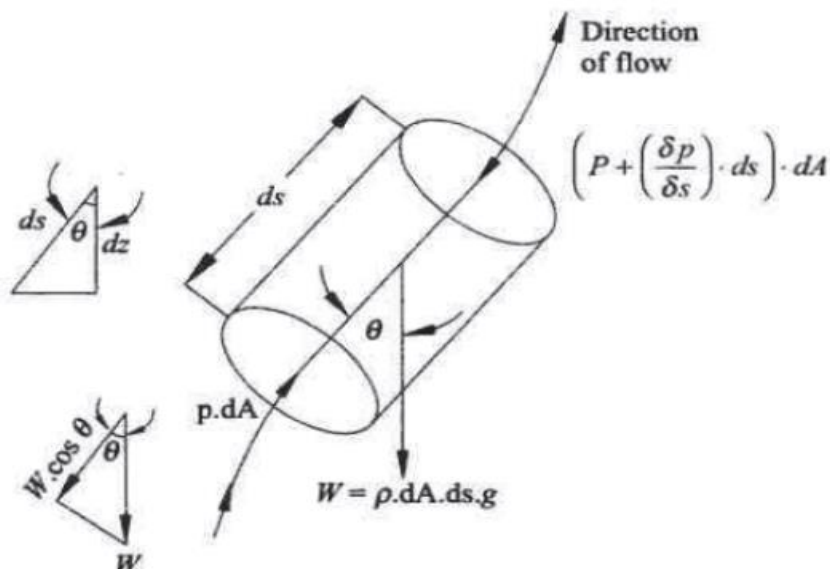

Let the area of cross section of the cylindrical element be dA , length of the cylindrical element be dS , let θ be the angle between the direction of the flow of fluid and the line of action of gravitational force on the element Then,

- 1.. the pressure forces along the direction of the flow – $p dA$
2. the pressure force opposite to the direction of the flow = $(p (\partial p/\partial s) ds) dA$

3. Gravitational force on the cylindrical element $p. dA. ds. g$
4. Component of the gravitational force opposite to the direction of flow = $\rho.dA.dS.g.\cos \theta$

The resultant force on the fluid element should be equal to the product of mass and the acceleration of the fluid element in the direction of the flow.

Net force in the direction of flow (mass of the fluid element) x (acceleration of the fluid element in the direction of flow)

Hence,

$$\rho.dA-(p(\partial p/\partial s) ds) dA- \rho.dA.dS.g.\cos \theta = \rho.dA.dS.(dV/dt).....(1)$$

Vis a function of(s, t)

$$a, = dV/dt = (\partial v/\partial s).(ds/dt) + (\partial v/\partial t) (dt/dt) = (\partial v/\partial s).(ds/dt) + (\partial v/\partial t) \quad \text{[for steady flow}$$

$$(\partial v/\partial t) = 0]$$

$$dV/dt = (\partial v/\partial s).V \quad \text{[(ds/dt) = V]}$$

$$\text{or } dV/dt = V. dV/ds.....(2)$$

Substituting the value of Eq.1 and 2

$$-((\partial p/\partial s)ds)dA- \rho dAdsg\cos \theta = \rho dAds. VdV/ds$$

$$-dp- \rho ds.\cos \theta.g- \rho VdV=0$$

$$dp + \rho dz.g + \rho VdV = 0 \quad \text{[: } \cos \theta = dz/ds]$$

$dz/ds]$

Integrating the above relation

$$\int dp + \int \rho g.dz + \int \rho VdV = \text{constant}$$

$$p+ \rho gz+ V^2/2=\text{constant}$$

Dividing the above relation by ρg

$$p/(\rho g)+ V^2/2g+ z =\text{constant.}$$

The following assumptions are made in deriving the Bernoulli's equation

1. The fluid flow is steady.
2. The fluid is ideal (non-viscous).
3. The fluid flow is incompressible.
4. The fluid flow is irrotational.

5. Velocity of the fluid particle across any cross section of the tube is constant.

R.G.P.V. solve problem

Q.1 A pipe 200 m long has a slope of 1 in 100 and tapers from 1 m diameter at the high end to 0.4 m at the low end. Rate of water flow is 4000 litres per minute. If the pressure at the high end is 50 kPa, find the pressure at the low end. **[R.G.P.V. Jan./Feb. 2008(10 marks)]**

Sol. Given

$L = 100$ m.

Slope = 1 in 100

$d_1 = 1$ m

$d_2 = 0.4$ m

$Q = 4000$ litres/min

$P_1 = 50$ kPa

$$\text{Area } A_1 = \frac{\pi}{4} D_1^2 = \frac{\pi}{4} 1^2 = \mathbf{0.7854 \text{ m}^2}$$

Pressure at the upper end = 50 kPa = 50 kN/m² = 50 × 10³ N/m²

$$\text{Area } A_2 = \frac{\pi}{4} d_2^2 = \frac{\pi}{4} (0.4)^2 = \mathbf{0.1257 \text{ m}^2}$$

Rate of flow $Q = 4000$ Litres/min or $4000/60 = 66.67$ lit./sec or $66.67/1000 = 0.07$ m³/sec

Let the datum line passing through the centre of the lower end.

Then $Z_2 = 0$

As slope is 1 in 100 means

$$Z_1 = \frac{1}{100} \times 200 = 2 \text{ m}$$

We know that

$$Q_1 = A_1 V_1 = A_2 V_2$$

$$V_1 = \frac{Q}{A_1} = \frac{0.07}{0.7854} = 0.089 \text{ m/sec}$$

$$V_2 = \frac{Q}{A_2} = \frac{0.07}{0.1257} = 0.5569 \text{ m/sec}$$

Applying Bernoulli's equation at sections 1 and 2, we get

$$\frac{P_1}{\rho g} + \frac{v_1^2}{2g} + Z_1 = \frac{P_2}{\rho g} + \frac{v_2^2}{2g} + Z_2$$

$$\frac{50 \times 10^3}{1000 \times 9.81} + \frac{(0.089)^2}{2 \times 9.81} + 2 = \frac{P_2}{1000 \times 9.81} + \frac{(0.5569)^2}{2 \times 9.81} + 0$$

$$5.097 + 4.037 + 10^{-4} + 2 = \frac{P_2}{9810} + 0.0158$$

$$P_2 = 69470.5 \text{ N/m}^2$$

$$P_2 = 69.47 \text{ KN/m}^2$$

$$= 69.47 \text{ KPa} \quad \text{Ans.}$$

Q.2 The water is flowing through a pipe having diameters 20 cm at inlet section 1 and 10 cm at outlet section 2. The rate of flow through pipe is 35 litres/sec. The section 1 is 6 m above datum and section 2 is 4 m above datum. If pressure at section 1 is 39.24 N/cm², find the intensity of pressure at section 2.

[R.G.P.V. ,April 2009 (10 marks)]

Sol. Given , $d_1 = 20 \text{ cm} = 0.2 \text{ m}$, $d_2 = 10 \text{ cm} = 0.1 \text{ m}$, $Q = 35 \text{ litres/sec} = 0.035 \text{ m}^3/\text{sec}$, $Z_1 = 6 \text{ m}$, $Z_2 = 4 \text{ m}$, $p_1 = 39.24 \text{ N/cm}^2 = 39.24 \times 10^4 \text{ n/m}^2$

Cross sectional area of the pipe at section 1,

$$\begin{aligned} \text{Area } A_1 &= \frac{\pi}{4} d_1^2 \\ &= \frac{\pi}{4} (0.2)^2 \\ &= 0.0314 \text{ m}^2 \end{aligned}$$

Cross sectional area of the pipe at section 2,

$$\begin{aligned} \text{Area } A_2 &= \frac{\pi}{4} d_2^2 \\ &= \frac{\pi}{4} (0.1)^2 = 0.00785 \text{ m}^2 \end{aligned}$$

$$\text{Velocity of flow section 1, } V_1 = \frac{Q}{A_1} = \frac{0.035}{0.0314} = 1.11 \text{ m/sec}$$

Velocity of flow section 2, $V_2 = \frac{Q}{A_2} = \frac{0.035}{0.00785} = 4.46 \text{ m/sec}$

Applying Bernoulli's equation at sections 1 and 2, we get

$$\frac{P_1}{\rho g} + \frac{v_1^2}{2g} + Z_1 = \frac{P_2}{\rho g} + \frac{v_2^2}{2g} + Z_2$$

$$\frac{39.24 \times 10^4}{1000 \times 9.81} + \frac{(1.11)^2}{2 \times 9.81} + 6 = \frac{p_2}{1000 \times 9.81} + \frac{(4.46)^2}{2 \times 9.81} + 4$$

$$40 + 0.0628 + 6 = \frac{p_2}{9810} + 1.0138 + 4$$

$$\frac{p_2}{9810} = 41.049$$

$$\begin{aligned} p_2 &= 41.049 \times 9810 \\ &= 402690.69 \text{ N/m}^2 \\ &= \mathbf{40.27 \text{ N/m}^2} \quad \text{Ans.} \end{aligned}$$

Q.3 The water is flowing through a pipe having diameters 25 cm and 10 cm at section 1 and 2 respectively. The rate of flow of water through the pipe is 30 litres/sec. Section 1 is 10 m above the ground and section 2 is 2 m above the ground. If pressure at section 1 is 40 N/cm², find the pressure at section 2. **[R.G.P.V., Dec. 2008(10 marks)]**

Sol. Given. $d_1 = 25 \text{ cm} = 0.25 \text{ m}$, $d_2 = 10 \text{ cm} = 0.10 \text{ m}$, $Q = 30 \text{ litres/sec} = 0.03 \text{ m}^3/\text{sec}$. $Z_1 = 10 \text{ m}$, $Z_2 = 2 \text{ m}$, $p_1 = 40 \text{ N/cm}^2 = 40 \times 10^4 \text{ N/m}^2$.

Cross sectional area of the pipe at section 1,

$$\text{Area } A_1 = \frac{\pi}{4} d_1^2$$

$$\begin{aligned} &= \frac{\pi}{4} (0.25)^2 \\ &= 0.0491 \text{ m}^2 \end{aligned}$$

Cross sectional area of the pipe at section 2,

$$\begin{aligned} \text{Area } A_2 &= \frac{\pi}{4} d_2^2 \\ &= \frac{\pi}{4} (0.1)^2 = 0.00785 \text{ m}^2 \end{aligned}$$

$$\text{Velocity of flow section 1, } V_1 = \frac{Q}{A_1} = \frac{0.03}{0.0491} = 0.61 \text{ m/sec}$$

$$\text{Velocity of flow section 2, } V_2 = \frac{Q}{A_2} = \frac{0.03}{0.00785} = 3.82 \text{ m/sec}$$

Applying Bernoulli's equation at sections 1 and 2, we get

$$\frac{P_1}{\rho g} + \frac{v_1^2}{2g} + Z_1 = \frac{P_2}{\rho g} + \frac{v_2^2}{2g} + Z_2$$

$$\frac{40 \times 10^4}{1000 \times 9.81} + \frac{(0.61)^2}{2 \times 9.81} + 10 = \frac{p_2}{1000 \times 9.81} + \frac{(3.82)^2}{2 \times 9.81} + 2$$

$$40.77 + 0.01896 + 10 = \frac{p_2}{9810} + 0.744 + 2$$

$$\frac{p_2}{9810} = 48.045$$

$$p_2 = 48.045 \times 9810$$

$$= 471321.45 \text{ N/m}^2$$

$$= \mathbf{47.132 \text{ N/cm}^2} \quad \text{Ans.}$$

Laminar and turbulent flow [RGPV Dec 08, June 08, Sep 09]

To understand the laminar and turbulent flow, consider Reynold's experimental set up Fig. consisting of the following essential parts:

1. Tank containing water maintained at a constant head.
2. Horizontal pipe made of glass tube and bell mouthed as shown in figure.
3. Regulating valve for controlling the flow of water, connected at the end of glass tube.
4. Small dye tank for injecting dye along the axis of the glass tube.

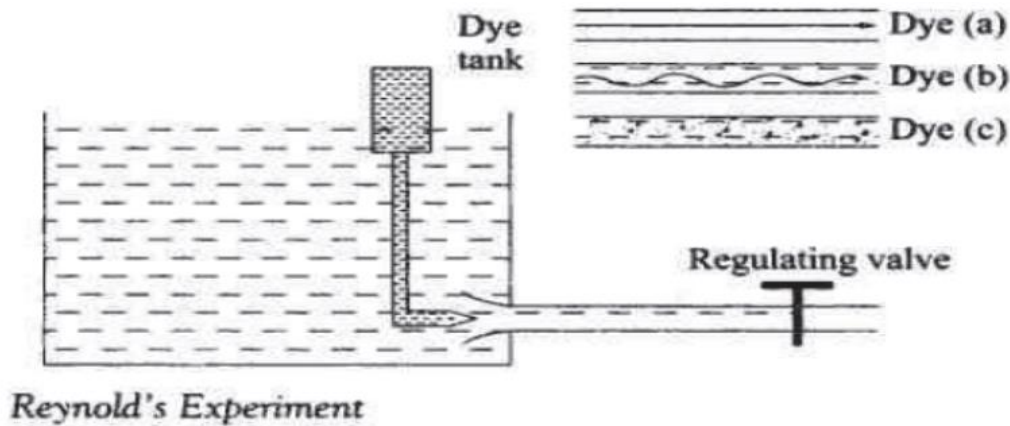

The water from the tank is allowed to flow through the glass tube. A liquid dye (same specific weight) is injected in the centre of the glass tube along the axis. The valve is opened slowly. As the flow velocity is low initially, the dye filament injected in the glass tube is flowing in a straight line parallel to the glass tube. Indicating it is a laminar flow Fig. (a).

With further opening of the valve, velocity of flow increases. The dye injected in the centre of the tube now no more follows a straight line path. but becomes wavy as shown in figure (b). This shows that the flow is no longer laminar. With further opening of the valve the velocity of flow further increases, a stage comes when the dye injected breaks up and finally diffuses in the water. This indicates that the fluid particles are moving in random fashion, in zig-zag path or disorderly manner causing the flow to become turbulent as shown in figure (c).

Laminar Flow In a laminar flow the fluid particles move along a well defined path or in streamline which are parallel and straight. Thus. The particles of fluid move in layers. The laminar flow is also called viscous or streamlines flow.

Turbulent Flow In a turbulent flow the fluid particles move in zigzag, erratic and unpredictable path due to which eddies are formed. A non-dimensional Reynolds's Number is used to determine whether the flow is laminar or turbulent. Reynolds's Number is defined as the ratio of inertia forces to the viscous forces of the flowing fluid.

$$R = \rho vd/\mu$$

Where density of flowing fluid ρ kg/m³

μ is the dynamic viscosity N-s/m²

d diameter of the pipe m

V velocity of fluid m/s

In pipes, if
 Reynolds's Number ≤ 2000 Laminar flow
 Reynolds's Number is greater than 2000 and less than 3000; it is Transition flow
 (neither
 laminar nor turbulent)
 Reynolds's Number ≥ 3000 Turbulent flow

Fluid coupling [June 08,12 (10,7 marks)]

The basic purpose of the fluid coupling is to transmit power from the driving shaft to the driven shaft without any mechanical coupling between them. It also serves the same purpose as served by the mechanical transmission systems like clutch assembly and gear train. In the mechanical power driven system, if the driver shaft rotates the driven shaft will rotate. The operating principle can be understood by an illustration. Keep two electric fans face to face at a small distance. Start one of the fans so that the air thrown by it is towards the other stationary fan. When the air thrown by the running fan towards the stationary fan create sufficient torque so as to overcome the friction and inertia forces of the stationary fan, the stationary fan also starts rotating but in the opposite direction. In this the working medium was air.

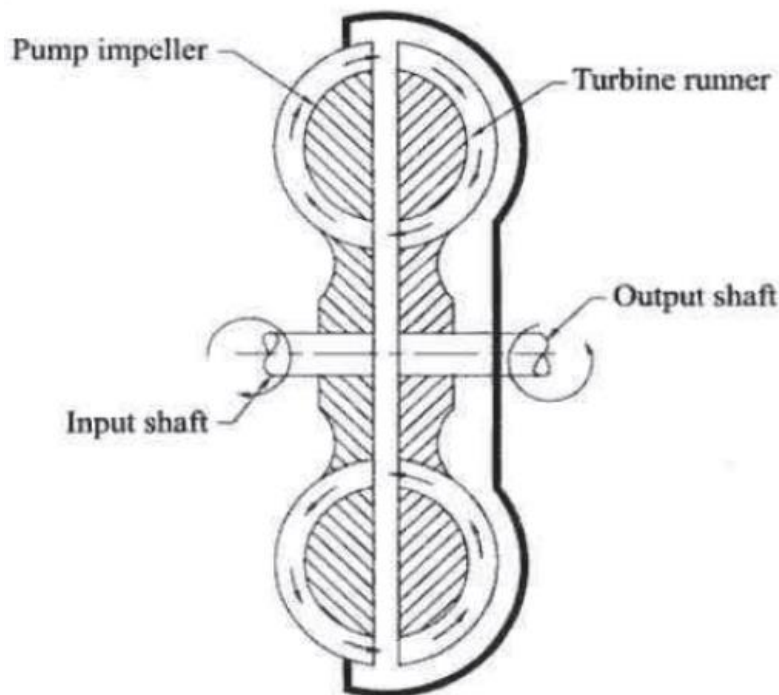

Figure shows the basic components of the fluid coupling. Normally, oil is used as a working medium due to its stability, non-corrosive and lubricating property. The

pump impeller and the turbine runner are enclosed in a single housing. Both are mounted on two different shafts as shown. The only contact between the two is the working fluid contained in the casing. When the driving shaft is rotated, because of centrifugal action the fluid moves from inner radius of the pump impeller to outer radius and gains the kinetic and potential energy. This fluid, then enters the outer radius of the turbine runner towards the inner rather and exerts a force on the turbine runner (blade) causing it to rotate. The fluid from the turbine runner once again enters the pump impeller and the process is repeated.

PUMPS

[RGPV june08, Sep 09]

Pump is a device which converts the mechanical energy into the energy of the fluid. In other words, it is a device which gives energy to the fluid thereby increasing its pressure head or kinetic head or both. Pumps are used for agriculture purposes, water supply systems, hydraulic control systems, and in many engineering applications.

Classification of Pumps

Pumps are classified as two types

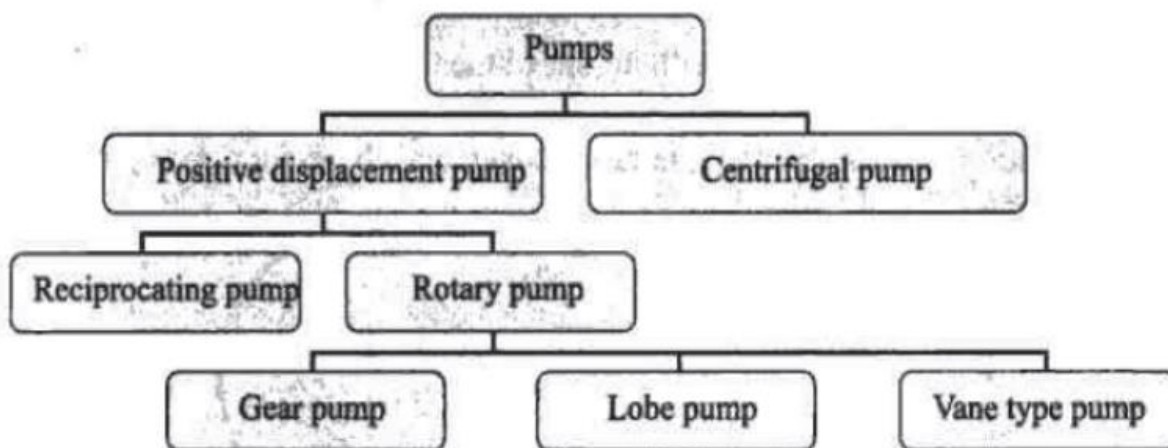

Reciprocating Pump

Figure shows the basic components of the reciprocating pump. The rotary motion given to the crank shaft by prime mover is converted into reciprocating motion of the piston by the connecting rod. When the piston moves from the outer dead centre to the inner dead centre, the inlet valve opens and fluid is drawn in to the cylinder through the inlet valve through the suction pipe. When the piston moves from inner

dead centre to outer dead centre, the pressure of fluid increases, this causes the pressure difference across the outlet valve and thereby opening it. As the outlet valve opens the fluid is forced out through the outlet valve to the delivery pipe. This cycle is repeated. If the fluid enters only from one side of the piston it is called single acting, if the fluid enters from both sides of the piston it is called double acting pump.

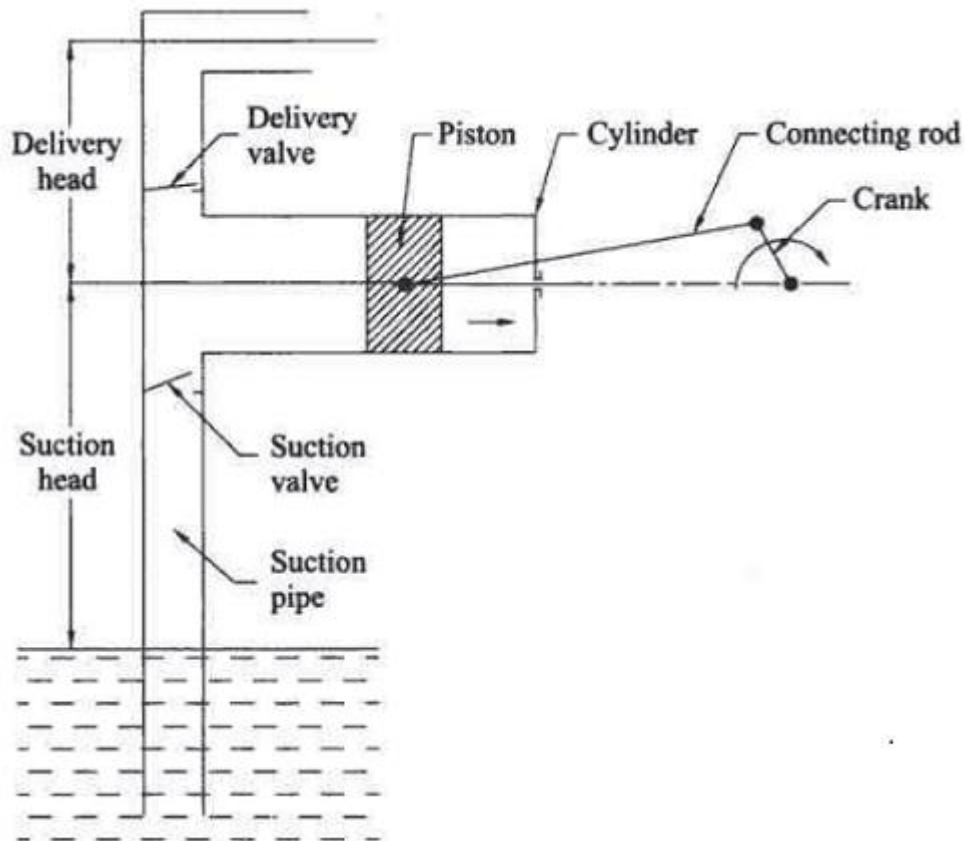

Main components of reciprocating pump

Rotary Pump

Gear Pump Figure shows the basic components of the gear pump. It consists of two placed in a stationary housing. One gear is keyed identical intermeshing spur gears. Both the gears are mounted on two different shafts and are to the driving shaft while the other revolves idly. The fluid entering the inlet port fills the space between the teeth. The fluid trapped between the teeth is carried forward by the revolving gears and finally pushed out of the discharge port. These are used in automobiles

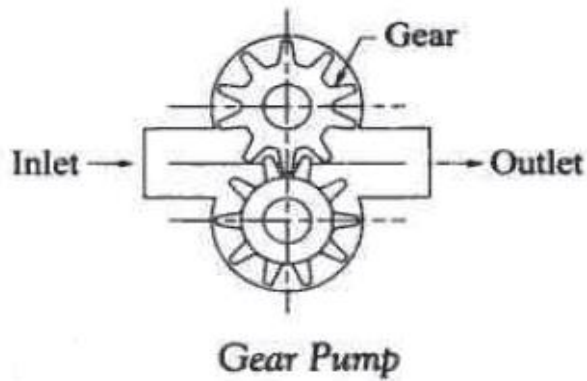

Lobe Pump Figure shows the basic components of the lobe pump. It consists of two identical lobes. Both the lobes are mounted on two different shafts and are placed in housing. One lobe is keyed to the driving shaft while the other revolves freely on the shaft. The fluid entering the inlet port fills the space between the two lobes. The fluid trapped between the lobes is carried forward by the rotating lobes and finally pushed out of the outlet port.

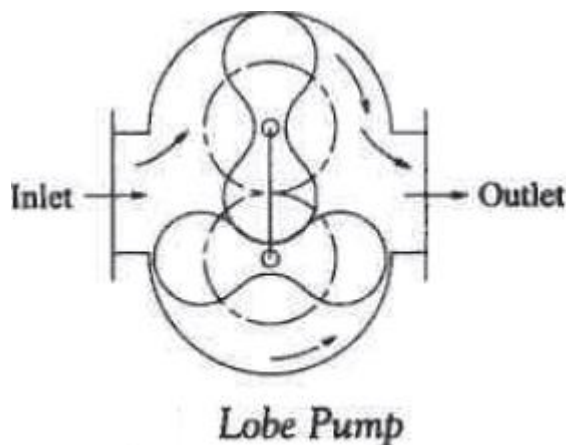

Vane Type Pump it consists of a rotor mounted eccentrically in relation to the cylindrical housing Fig. The rotor has slots cut radially in which the vanes Vane slide. The vanes are spring loaded, i.e., the vanes arc held tightly against the cylindrical housing by means of spring. It Fig. Vane pump provides the leak proof joint between the suction and discharge connection. When the rotor rotates, the vane moves to and fro inside the slot of the rotor. During the suction, the space between the vanes increases. During the further movement of the rotor the space decreases and the fluid is discharged.

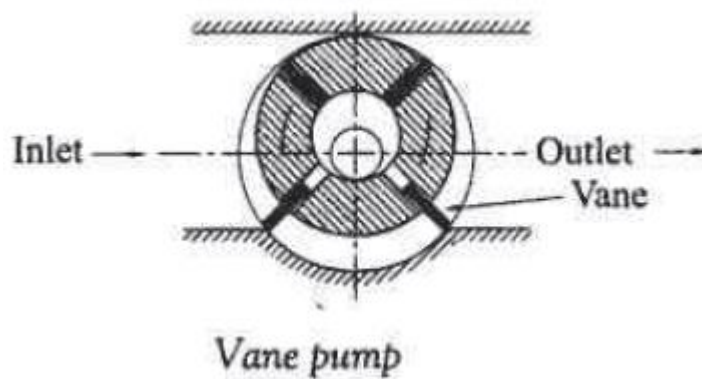

Centrifugal Pump

The essential parts of the centrifugal pump and Centrifugal pump assembly are as follows and are shown in Fig.

Impeller: Impeller consists of series of curve blades mounted on the shaft as shown in figure. It is coupled to an electric motor or a prime mover.

Casing: The casing is air tight passage surrounding the impeller of a pump. The high kinetic energy imparted to the fluid at the outlet of the impeller is converted into pressure energy in a spiral casing of gradually increasing cross-section area.

Suction pipe: it is a pipe whose one end is connected to the inlet of a pump called an eye of the pump, while the other end is connected to the water sump. It is provided with a foot valve (one way valve) to prevent the back flow of water into the sump, when the pump is stopped. Below the foot valve a strainer is provided to prevent the entry of dust particles, debris. etc., into the pump.

Delivery pipe: Delivery pipe leads the fluid from the outlet of the pump to the point of use. Generally, a valve is provided to control the flow of fluid into the delivery pipe at the outlet.

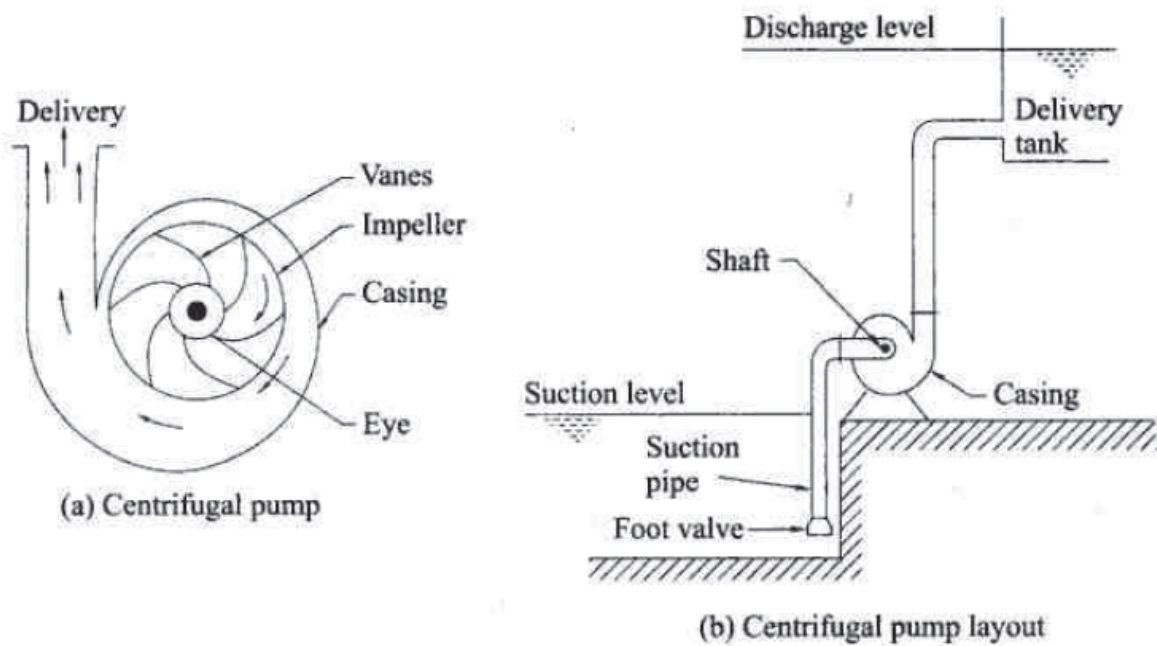

AIR COMPRESSOR [RGPV, Dec.13, June 11(14,7 marks)]

Introduction

The function of compressor is to compress certain quantity of air or gas from the suction pressure to a required delivery pressure, In order to compress air or gas certain amount of energy is required, hence it is necessary that the air should be compressed with minimum expenditure of energy. A compressor requires a prime mover which can be electric motor or in some cases internal combustion engines. The compressed air finds many applications because of easy transmission of compressed air. Some of the applications of compressed air are in operation of pneumatic drill, hammers, hoist. Control system. Air brakes, sprays. Blast furnaces and lift gates. Compression of air plays a vital role in the performance of internal combustion engine and gas turbines. Compressors also find its application in refrigeration and air conditioning industries.

Classification of Compressors

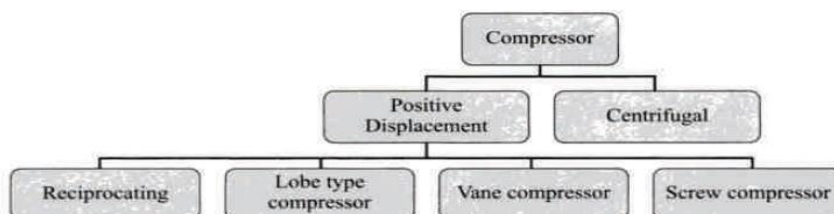

Reciprocating Compressor

The basic components of reciprocating compressor are piston, cylinder and connecting rod whose one end is connected to the piston and the other big end connected to the crank Fig. The inlet and outlet valves are also provided with the cylinder head which are operated by the pressure differences across them. In general, the piston reciprocates inside the cylinder which is either air cooled or water cooled. When the piston moves in the downward direction the air trapped between the piston and the cylinder in the previous stroke (air in the clearance volume) expands and the pressure inside the cylinder decreases. As soon as the pressure inside the cylinder reaches a value less than the intake manifold pressure the inlet valve opens. Thus a fresh charge of air is sucked inside the cylinder, for the remaining part of then suction stroke, During this process the delivery or the outlet valve remains closed. When the piston moves in the upward direction the pressure inside the cylinder increases, and as soon as the pressure inside the cylinder reaches a value more than the intake manifold pressure the inlet valve is closed. The further upward movement of the piston increases the pressure of the air trapped inside the piston and the cylinder. Eventually, a pressure will be reached when the pressure inside the cylinder becomes more than the delivery pressure. This pressure difference causes opening of the delivery valve and the compressed air is delivered to the receiver for the remaining pair of the stroke. After completion of the compression stroke piston once again moves in the downward direction and the cycle is repeated.

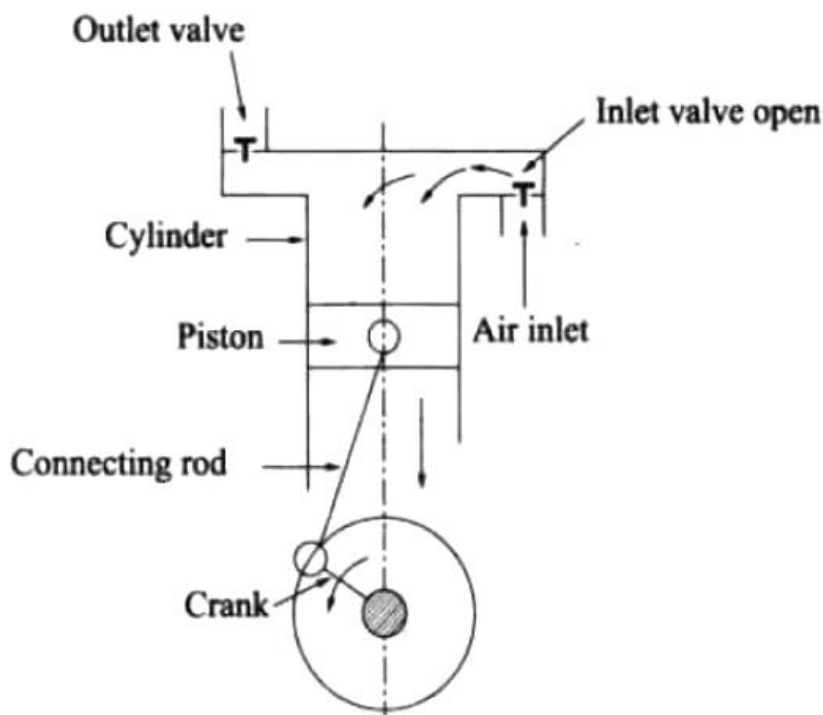

Rotary Compressors

Lobe type root blower Figure shows the basic components of the lobe pump. It consists of two identical lobes. Both the lobes are mounted on two different shafts and arc placed in housing. One lobe is keyed to the driving shaft while the other revolves freely on the shall. The profile of the lobe is cycloid or involute. The air entering the inlet port fills the space between the two lobes. The air trapped between the lobes is carried forward by the rotating lobes and finally pushed out of the outlet port, As each side of the lobe faces a side of casing, the process is carried out four times per revolution of the driving shaft.

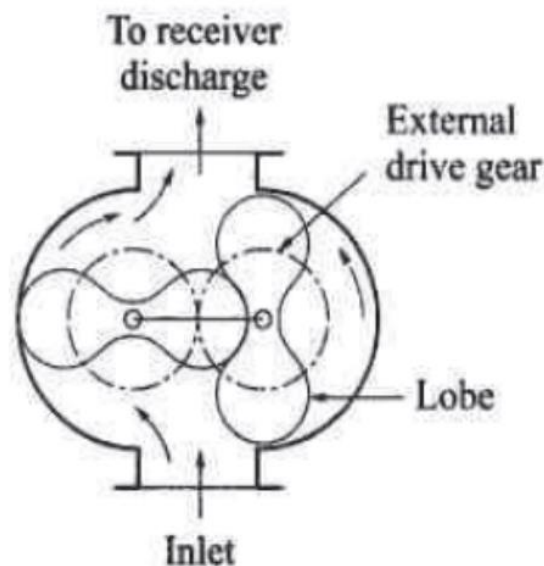

Vane Type Blower

Vane Type Blower: it consists Of a rotor mounted eccentrically in relation to the cylindrical housing. Fig. 3.36. The rotor has slots cut radially in which the vanes slide. The vanes are spring loaded, i.e., the vanes are held tightly against the cylindrical housing by means of spring It provides the leak-proof joint between the suction and discharge connection. When rotor rotates the vane moves to and fro in the slot of the rotor. During the suction, the space between the vanes increases. During the further movement of the rotor the space and the casing decreases and air is discharged through the outlet. In this type of compression the compression is obtained before the trapped volume is opened to the delivery. and further compression is obtained by the back flow of air from the receiver.

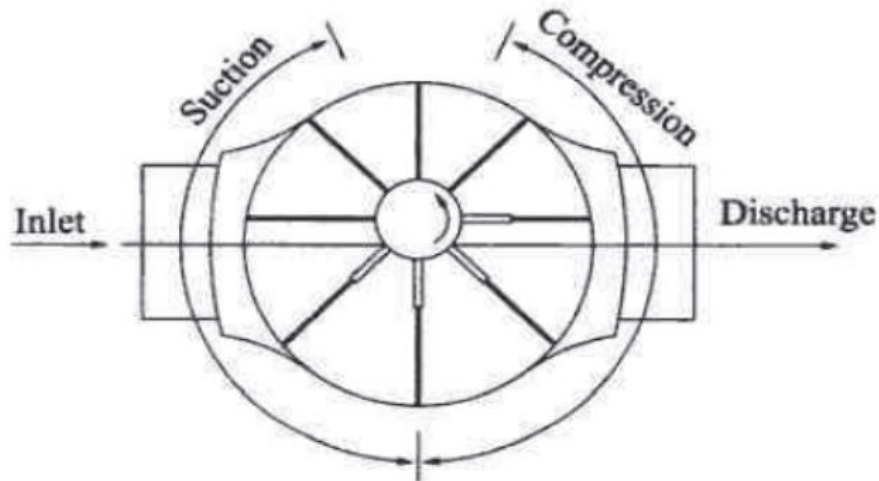

Centrifugal Compressor

The essential parts of the centrifugal pump are shown in Fig. and are same as that of centrifugal pump. It consists of a rotor with a series of curved blades. Air is drawn in through an opening near the hub as shown in Fig.. The impeller rotates at high rotational speed. The static pressure of air increases from an eye to an impeller outlet. As the air leaving an impeller tip is passed through a diffuser provided around an impeller. The kinetic energy of the air is thus converted into the pressure energy. The centrifugal compressors are used for low pressure and high volume of air.

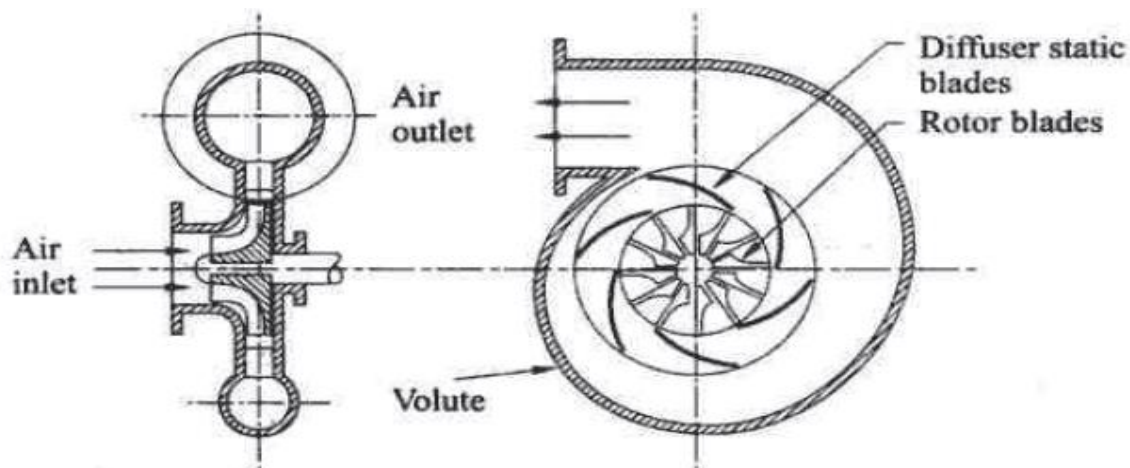

TURBINES [RGPV jan/feb 08, April 09]**Introduction**

A water turbine converts the available potential and kinetic energy of the water into useful mechanical energy. The rotary motion imparted to the turbine in turn is used to drive an electric generator. Thus, it converts mechanical energy into electric energy.

Turbines are classified as:

1. (a) Impulse turbine e.g., Pelton
(b) Reaction turbine e.g., Francis turbine, Kaplan turbine
2. According to available head
 - (a) Low head: less than 30 m e.g., Kaplan turbine
 - (b) Medium head: $30 \text{ m} < \text{head} < 100 \text{ m}$ Kaplan turbine, Francis turbine
 - (c) High head: $\text{head} > 100 \text{ m}$, Pelton turbine
3. According to the direction of flow of water
 - (a) Tangential flow, e.g., Pelton turbine
 - (b) Radial flow, e.g., Francis turbine
 - (e) Axial flow, e.g., Kaplan turbine

Impulse turbine**Pelton turbine [RGPV Jan./feb.2008(5 marks)]**

The only hydraulic turbine of the impulse type in common use, is named after an American engineer Laster A Pelton, who contributed much to its development around the year 1880. Therefore this machine is known as Pelton turbine or Pelton wheel. It is an efficient machine particularly suited to high heads. The rotor consists of a large circular disc or wheel on which a number (seldom less than 15) of spoon shaped buckets are spaced uniformly round its periphery as shown in Figure 26.1. The wheel is driven by jets of water being discharged at atmospheric pressure from pressure nozzles. The nozzles are mounted so that each directs a jet along a tangent to the circle through the centres of the buckets (Figure 26.2). Down the centre of each bucket, there is a splitter ridge which divides the jet into two equal streams which flow round the smooth inner surface of the bucket and leaves the bucket with a relative velocity almost opposite in direction to the original jet. For maximum change in momentum of the fluid and hence for the maximum driving force on the wheel, the deflection of the water jet should be 180° . In practice, however, the deflection is limited to about 165° so that the water leaving a bucket

may not hit the back of the following bucket. Therefore, the camber angle of the buckets is made as 165° ($\theta = 165^\circ$). Figure(26.3a)

The number of jets is not more than two for horizontal shaft turbines and is limited to six for vertical shaft turbines. The flow partly fills the buckets and the fluid remains in contact with the atmosphere. Therefore, once the jet is produced by the nozzle, the static pressure of the fluid remains atmospheric throughout the machine. Because of the symmetry of the buckets, the side thrusts produced by the fluid in each half should balance each other.

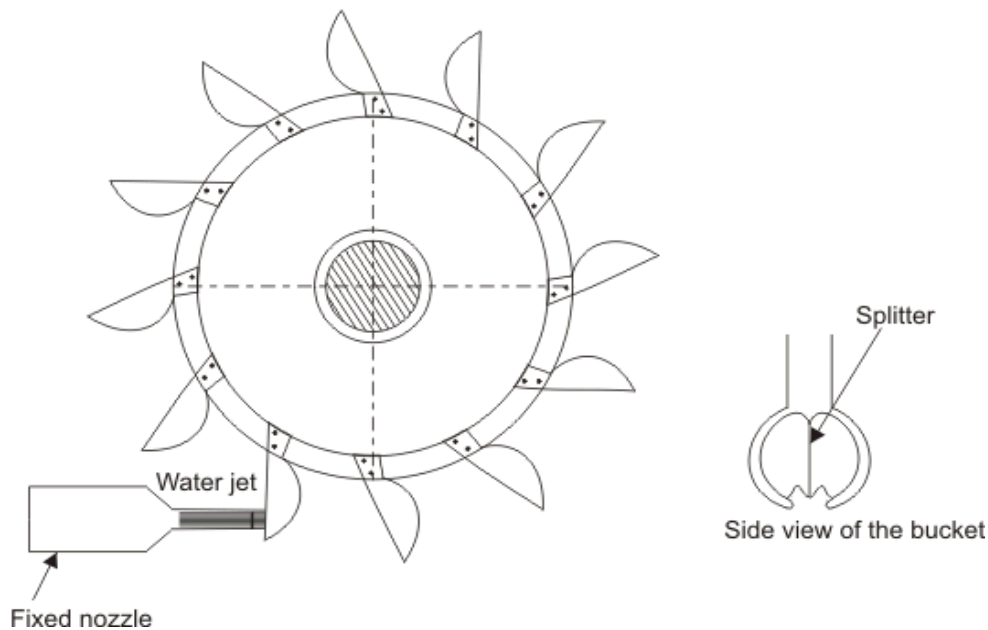

Reaction Turbine:

Francis Turbine

The principal feature of a reaction turbine that distinguishes it from an impulse turbine is that only a part of the total head available at the inlet to the turbine is converted to velocity head, before the runner is reached. Also in the reaction turbines the working fluid, instead of engaging only one or two blades, completely fills the passages in the runner. The pressure or static head of the fluid changes gradually as it passes through the runner along with the change in its kinetic energy based on absolute velocity due to the impulse action between the fluid and the runner. Therefore the cross-sectional area of flow through the passages of the fluid. A reaction turbine is usually well suited for low heads. A radial flow hydraulic turbine of reaction type was first developed by an American Engineer, James B. Francis

(1815-92) and is named after him as the Francis turbine. The schematic diagram of a Francis turbine is shown in Fig.

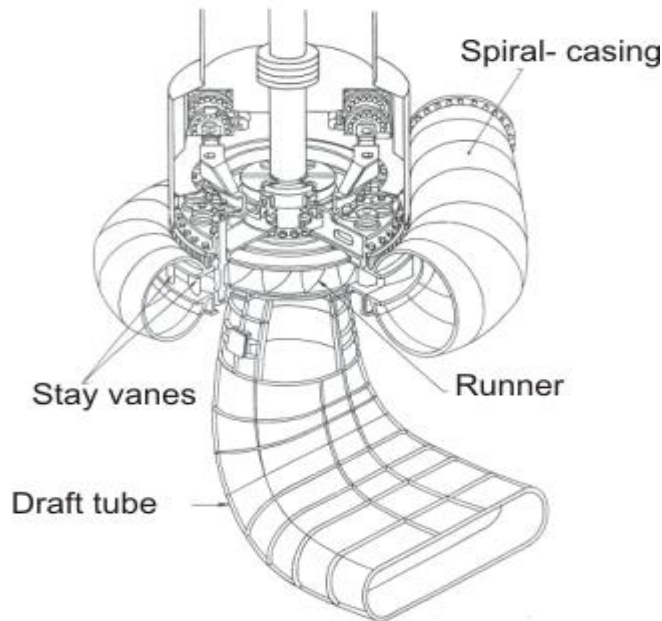

A Francis turbine comprises mainly the four components:

- (i) spirical casing,
- (ii) guide on stay vanes,
- (iii) runner blades,
- (iv) draft-tube as shown in Figure

Spiral Casing: Most of these machines have vertical shafts although some smaller machines of this type have horizontal shaft. The fluid enters from the penstock (pipeline leading to the turbine from the reservoir at high altitude) to a spiral casing which completely surrounds the runner. This casing is known as scroll casing or volute. The cross-sectional area of this casing decreases uniformly along the circumference to keep the fluid velocity constant in magnitude along its path towards the guide vane.

This is so because the rate of flow along the fluid path in the volute decreases due to continuous entry of the fluid to the runner through the openings of the guide vanes or stay vanes.

Guide or Stay vane:

The basic purpose of the guide vanes or stay vanes is to convert a part of pressure energy of the fluid at its entrance to the kinetic energy and then to direct the fluid on to the runner blades at the angle appropriate to the design. Moreover, the guide vanes are pivoted and can be turned by a suitable governing mechanism to regulate the flow while the load changes. The guide vanes are also known as wicket gates. The guide vanes impart a tangential velocity and hence an angular momentum to the water before its entry to the runner. The flow in the runner of a Francis turbine is not purely radial but a combination of radial and tangential. The flow is inward, i.e. from the periphery towards the centre. The height of the runner depends upon the specific speed. The height increases with the increase in the specific speed. The main direction of flow change as water passes through the runner and is finally turned into the axial direction while entering the draft tube.

Draft tube:

The draft tube is a conduit which connects the runner exit to the tail race where the water is being finally discharged from the turbine. The primary function of the draft tube is to reduce the velocity of the discharged water to minimize the loss of kinetic energy at the outlet. This permits the turbine to be set above the tail water without any appreciable drop of available head. A clear understanding of the function of the draft tube in any reaction turbine, in fact, is very important for the purpose of its design. The purpose of providing a draft tube will be better understood if we carefully study the net available head across a reaction turbine.

Net head across a reaction turbine and the purpose to providing a draft tube.

The effective head across any turbine is the difference between the head at inlet to the machine and the head at outlet from it. A reaction turbine always runs completely filled with the working fluid. The tube that connects the end of the runner to the tail race is known as a draft tube and should completely to filled with the working fluid flowing through it. The kinetic energy of the fluid finally discharged into the tail race is wasted. A draft tube is made divergent so as to reduce the velocity at outlet to a minimum. Therefore a draft tube is basically a diffuser and should be designed properly with the angle between the walls of the tube to be limited to about 8 degree so as to prevent the flow separation from the wall and to reduce

accordingly the loss of energy in the tube. Figure 28.3 shows a flow diagram from the reservoir via a reaction turbine to the tail race.

KAPLAN TURBINE [RGPV, June 11 (7 marks)]

The Kaplan turbine is an inward flow reaction turbine, which means that the working fluid changes pressure as it moves through the turbine and gives up its energy. Power is recovered from both the hydrostatic head and from the kinetic energy of the flowing water. The design combines features of radial and axial turbines.

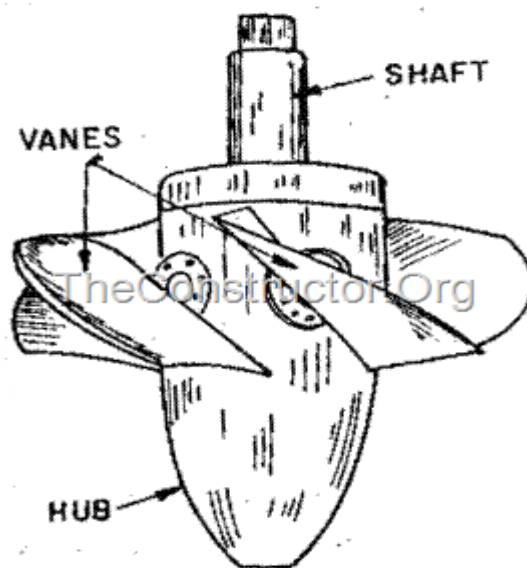

The inlet is a scroll-shaped tube that wraps around the turbine's wicket gate. Water is directed tangentially through the wicket gate and spirals on to a propeller shaped runner, causing it to spin. The outlet is a specially shaped draft tube that helps decelerate the water and recover kinetic energy. The turbine does not need to be at the lowest point of water flow as long as the draft tube remains full of water. A higher turbine location, however, increases the suction that is imparted on the turbine blades by the draft tube. The resulting pressure drop may lead to cavitations. Variable geometry of the wicket gate and turbine blades allow efficient operation for a range of flow conditions. Kaplan turbine efficiencies are typically over 90%, but may be lower in very low head applications.

HYDROELECTRIC POWER PLANT

Water flowing in the river is comprised of kinetic energy and potential energy. The basic principle of hydropower is that if water can be piped from a certain level to a lower level, then the resulting water pressure can be used to do work. If the water

pressure is allowed to move a mechanical component then that movement involves the conversion of the potential energy of the water into mechanical energy. Hydro turbines convert water pressure into mechanical shaft power, which can be used to drive an electricity generator, a grinding mill or some other useful device.

There several important components of the hydroelectric power plant.

Hydroelectric Dam

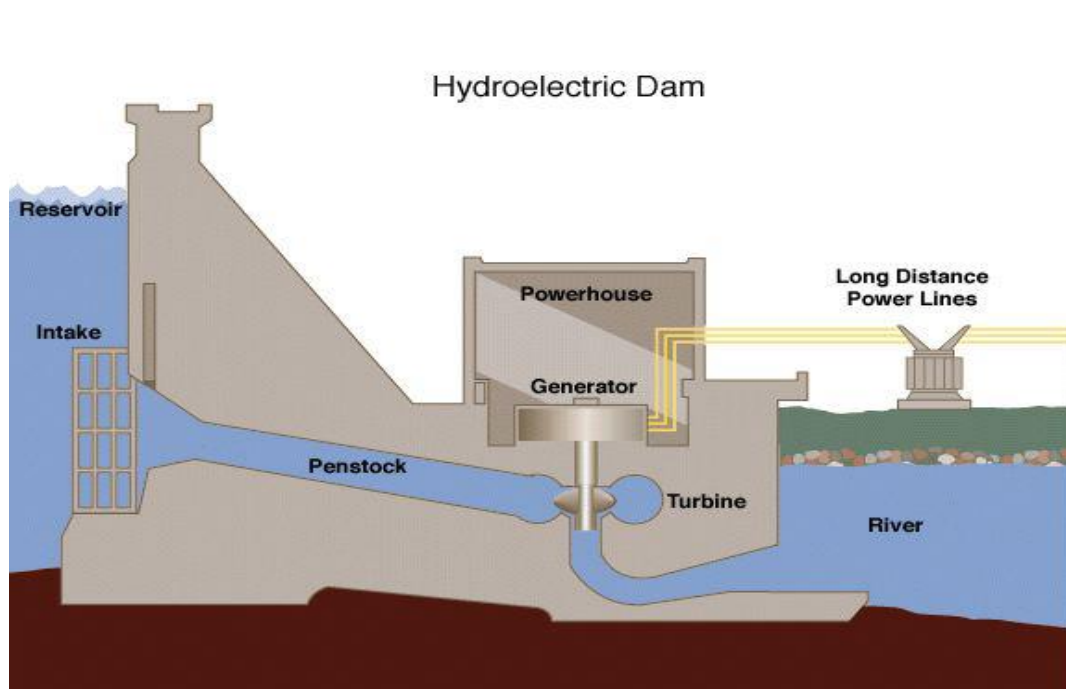

1) Dam

The dam is the most important component of hydroelectric power plant. The dam is built on a large river that has abundant quantity of water throughout the year. It should be built at a location where the height of the river is sufficient to get the maximum possible potential energy from water.

2) Water Reservoir

The water reservoir is the place behind the dam where water is stored. The water in the reservoir is located higher than the rest of the dam structure. The height of water in the reservoir decides how much potential energy the water possesses. The higher the height of water, the more its potential energy. The high position of water in the reservoir also enables it to move downwards effortlessly.

The height of water in the reservoir is higher than the natural height of water flowing in the river, so it is considered to have an altered equilibrium. This also helps to

increase the overall potential energy of water, which helps ultimately produce more electricity in the power generation unit.

3) Intake or Control Gates

These are the gates built on the inside of the dam. The water from reservoir is released and controlled through these gates. These are called inlet gates because water enters the power generation unit through these gates. When the control gates are opened the water flows due to gravity through the penstock and towards the turbines. The water flowing through the gates possesses potential as well as kinetic energy.

4) The Penstock

The penstock is the long pipe or the shaft that carries the water flowing from the reservoir towards the power generation unit, comprised of the turbines and generator. The water in the penstock possesses kinetic energy due to its motion and potential energy due to its height.

The total amount of power generated in the hydroelectric power plant depends on the height of the water reservoir and the amount of water flowing through the penstock. The amount of water flowing through the penstock is controlled by the control gates.

5) Water Turbines

Water flowing from the penstock is allowed to enter the power generation unit, which houses the turbine and the generator. When water falls on the blades of the turbine the kinetic and potential energy of water is converted into the rotational motion of the blades of the turbine. The rotating blades cause the shaft of the turbine to also rotate. The turbine shaft is enclosed inside the generator. In most hydroelectric power plants there is more than one power generation unit.

There is large difference in height between the level of turbine and level of water in the reservoir. This difference in height, also known as the head of water, decides the total amount of power that can be generated in the hydroelectric power plant.

There are various types of water turbines such as Kaplan turbine, Francis turbine, Pelton wheels etc. The type of turbine used in the hydroelectric power plant depends on the height of the reservoir, quantity of water and the total power generation capacity.

6) Generators

It is in the generator where the electricity is produced. The shaft of the water turbine rotates in the generator, which produces alternating current in the coils of the generator. It is the rotation of the shaft inside the generator that produces magnetic field which is converted into electricity by electromagnetic field induction. Hence the rotation of the shaft of the turbine is crucial for the production of electricity and this is achieved by the kinetic and potential energy of water. Thus in hydroelectricity power plants potential energy of water is converted into electricity.

Venturi meter

Venturi meter is commonly used flow meters for measuring mass/volumetric flow rate or velocity of the flowing fluid. These flow meters are also known as variable head meters. They are categorized as *full-bore meter* as measurement of the fluid takes place when it flows through a conduit or channel.

The venturi meter has a converging conical inlet, a cylindrical throat and a diverging recovery cone. It has no projections into the fluid, no sharp corners and no sudden changes in contour. The following figure shows the venturi meter with uniform cylindrical section before converging entrance, a throat and divergent outlet. The converging inlet section decreases the area of the fluid stream, causing the velocity to increase and the pressure to decrease. The low pressure is measured in the centre of the cylindrical throat as the pressure will be at its lowest value, where neither the pressure nor the velocity will be changing. As the fluid enters the diverging section the pressure is largely recovered lowering the velocity of the fluid. The major disadvantages of this type of flow detection are the high initial costs for installation and difficulty in installation and inspection.

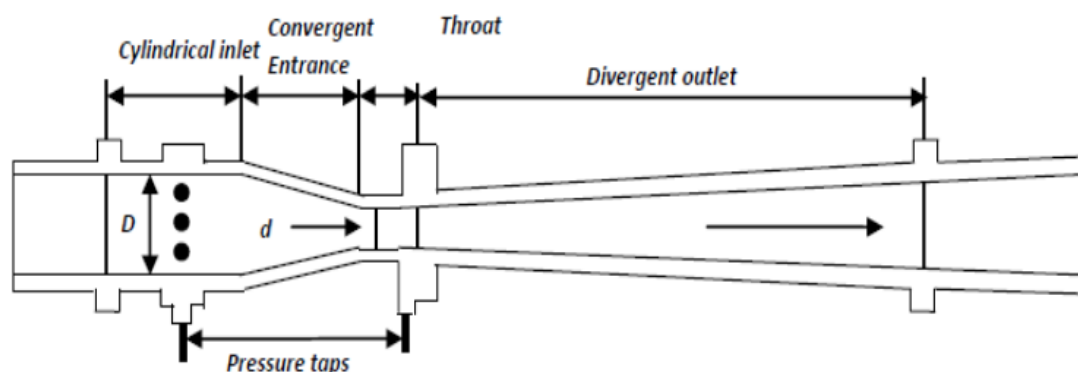

The *Venturi effect* is the reduction in fluid pressure that results when a fluid flows through a constricted section of pipe. The fluid velocity must increase through the

constriction to satisfy the equation of continuity, while its pressure must decrease due to conservation of energy: the gain in kinetic energy is balanced by a drop in pressure or a pressure gradient force. An equation for the drop in pressure due to Venturi effect may be derived from a combination of Bernoulli's principle and the equation of continuity. The equation for venturi meter is obtained by applying Bernoulli equation and equation of continuity assuming an incompressible flow of fluids through manometer tubes. If V_1 and V_2 are the average upstream and downstream velocities and ρ is the density of the fluid, then using Bernoulli's equation we get,

$$\alpha_2 V_2^2 - \alpha_1 V_1^2 = \frac{2g(P_a - P_b)}{\rho} \dots\dots\dots (1)$$

Where α_1 and α_2 are kinetic energy correction factors at two pressure tap positions. Assuming density of fluid to be constant, the equation of continuity can be written as:

$$V_1 = \left(\frac{D_2}{D_1}\right)^2 V_2 \dots\dots\dots (2)$$

Where D_1 and D_2 are diameter of pipe and throat in meters respectively. Eliminating V_1 from equation (1) and equation (2) we get,

$$V_2 = \frac{1}{\sqrt{\alpha_2 - \alpha_1 \beta^4}} \sqrt{\frac{2(P_1 - P_2)}{\rho}} \dots\dots\dots (3)$$

Where β is the ratio of the diameter of throat to that of diameter of pipe. If we assume a small friction lose between two pressure taps, the above equation (3) can be corrected by introducing empirical factor C_v and written as,

$$V_2 = \frac{C_v}{\sqrt{1 - \beta^4}} \sqrt{\frac{2(P_1 - P_2)}{\rho}} \dots\dots\dots (4)$$

The small effect of the kinetic energy factors α_1 and α_2 are also taken into account in the definition of C_v .

Volumetric flow rate Q_a can be calculated as:

$$Q_a = V_2 S_2 = \frac{C_v S_2}{\sqrt{1 - \beta^4}} \sqrt{\frac{2(P_1 - P_2)}{\rho}} \dots\dots\dots (5)$$

Where, S_2 is the cross sectional area of throat in m^2 . Substituting $(P_1 - P_2) = \rho g H$ in above equation (5) we get,

$$Q_a = V_2 S_2 = \frac{C_v S_2}{\sqrt{1 - \beta^4}} \sqrt{2g\Delta H} \dots\dots\dots (6)$$

Where ΔH is the manometric height difference * (specific gravity of manometric fluid – specific gravity of manometric fluid of water).



If you have any queries please visit- <https://studywithakash.in/>

Gmail – studywithakash311@gmail.com

+918871317984

THANK YOU