

## UNIT- 4

### Developing Writing skills

#### What is writing skills ?

Writing is a form of communication that allows students to put their feelings and ideas on paper, to organize their knowledge and beliefs into convincing arguments, and to convey meaning through wellconstructed text. In its most advanced form, written expression can be as vivid as a work of art.

#### Importance of writing skills

Writing is an essential job skill. Writing is the primary basis upon which one's work, learning, and intellect will be judged-in college, in the work place and in the community. Writing equips us with communication and thinking skills. ... Writing fosters our ability to explain and refine our ideas to others and ourselves.cted text. In its most advanced form, written expression can be as vivid as a work of art.

#### Three important stages in writing skills

##### 1.Planning

Usually, planning effectively before you write helps you to write effectively, which means you will have less editing to do later on. ... Imagine your topic was 'Evaluate the usefulness of a task analysis approach to assignment writing'. There are many ways of planning.

It is the planning phrase of the writing process. The Idea and Organization Traits are important in the prewriting phrase as the writer considers narrowing or expanding the writing focus and selects an organizational structure that will most effectively showcase the student's ideas.

What is the planning process in writing?

Prewriting is the planning phase of the writing process. During this phase, writers may plan for writing by drawing pictures, making lists, brainstorming, using graphic organizers, or conferring with a peer as they anticipate writing on a topic for a particular audience.

When the process of writing is more of an exploration - I'm thinking primarily of fiction here - then it's not necessary to plan in detail. You'll want to get some basics clear, though: your concept or theme, your main characters, and the ending. You'll probably also have some thoughts about key scenes or chapters that'll be included along the way.

## Better Planning

1. Plan as you go along (as well as before you start). If you get stuck mid-way, take a break from the actual writing and look at what you've already covered and where you're going next.
2. Keep a notebook. Use this as a place to record and explore ideas. Even if something doesn't fit this project, it might become part of the next one.

## 2. Drafting

Drafting is the preliminary stage of a written work in which the author begins to develop a more cohesive product. A draft document is the product the writer creates in the initial stages of the writing process. In the drafting stage, the author: develops a more cohesive text. organizes thoughts.

The drafting stage is characterized by increasingly less tentative efforts toward implementing a specific plan for written communication. The first draft takes shape according to the thesis or hypothesis, which serves as a clearly defined and articulated purpose for the work, and the outline or other form of graphic organization. With each successive draft, the work begins to assume more definitive form.

## 3.Editing

Editing involves looking at each sentence carefully, and making sure that it's well designed and serves its purpose. Proofreading involves checking for grammatical and punctuation errors, spelling mistakes, etc. Proofing is the final stage of the writing process.

Editing is the process of selecting and preparing written, visual, audible, and film media used to convey information. The editing process can involve correction, condensation, organization, and many other modifications performed with an intention of producing a correct, consistent, accurate and complete work.

## What is the purpose of editing in the writing process?

Editing involves looking at each sentence carefully, and making sure that it's well designed and serves its purpose. Proofreading involves checking for grammatical and punctuation errors, spelling mistakes, etc. Proofing is the final stage of the writing process.

## Importance of editing

The Importance of Editing. Whether it's performed by a peer, a professional, or the author, editing is by far the most crucial stage of the writing process. ... Writing without editing is like getting dressed with your eyes closed, and then leaving the house without looking in the mirror.

When you have revised a piece of writing for its content, you are ready to check it for its accuracy. This is called editing, and includes checking grammar, spelling, punctuation and capitalization.

**Editing is a stage of the writing skills in which a writer or editor strives to improve a draft by correcting errors and by making words and sentences clearer, more precise, and more effective.**

The process of editing involves adding, deleting, and rearranging words along with recasting sentences and cutting the clutter. Tightening our writing and mending faults can turn out to be a remarkably creative activity, leading us to clarify ideas, fashion fresh image, and even radically rethink the way we approach a topic.

## How to Improve Writing Skills [Summary]:

1. Brush up on the basic principles of writing, grammar and spelling.
2. Write like it's your job and practice regularly.
3. Read more so you develop an eye for what effective writing looks like.
4. Find a partner. Ask them to read your writing and provide feedback.
5. Join a workshop, meet up, or take a writing night class.
6. Take the time to analyze writing you admire.
7. Imitate writers you admire.
8. Outline your writing.
9. Edit your writing.

10. Accept that first drafts are often bad and revise.
11. Find an editor who demonstrates patience.
12. Eliminate unnecessary words from your writing.
13. Review your earlier work and see how you've grown.
14. Don't be afraid to say what you mean in what you write.
15. Make sure you do adequate research on your topic.
16. Don't delay writing. Get it done now.

## PRECIS WRITING

### Introduction

A précis is a summary. Précis writing is an exercise in compression. A précis is the gist of a passage expressed in as few words as possible. A précis should give all essential points so that anyone reading it will be able to understand the idea expressed in the original passage.

Note that précis writing is different from paraphrasing. In a paraphrase you should give all the details: you should not leave out any details. A paraphrase will be at least as long and sometimes longer than the original. A précis, on the other hand, must always be shorter than the original. It should express only the main theme that too as briefly as possible.

### How long should a précis be?

There are no rigid rules regarding the length of a précis. But as a general rule, it should not contain more than a third of the total number of words in the original passage.

### Uses of précis writing

Most people read carelessly and fail to fully comprehend the meaning of the passage. Précis writing forces them to pay attention to what they read because no one can write a summary of a passage unless they read it carefully. So summarizing teaches one to read with concentration.

Précis writing also improves your overall writing skills. It teaches you how to express your thoughts clearly, concisely and effectively. You learn to choose your words carefully and construct your sentences in a logical and concise manner.

### Steps in precise writing

The goal of a précis is to summarize the findings in an article by identifying the main points and conclusions of the research along with reviewing the broader implications of the results obtained in the passage.

In order to accomplish this goal, it helps to follow a six step process:

Step 1: Read the passage. Read it again. Go on reading it until you understand it. Put down on paper the main idea or central ideas; make notes in the margins.

Step 2: Read the passage again to make sure you haven't missed any important ideas.

Step 3: Referring to your notes if you need to, but not to the original, write a rough summary of the passage. By not looking at the original, you will avoid copying; you will be forced to put the ideas into your own words.

Step 4: Read your précis. Ask yourself the following questions-

Does it say what the original says?

Have you kept the connections of thought original?

Is the précis perfectly clear?

Can you improve or condense any words or phrases?

Step 5: Count the words. If there are too many, write more concisely to shorten the précis. If there are too few, check to see whether you omitted some important ideas.

Step 6: Read the précis again. If nothing important has been omitted and nothing at all added, write your final, correct copy. Proofread it.

### Step 7: Give the suitable title to your précis

Step 8: Write number of words in bracket below your precis

### Examples of précis writing

#### Example 1

It is physically impossible for a well-educated, intellectual, or brave man to make money the chief object of his thoughts just as it is for him to make his dinner the principal object of them. All healthy people like their dinners, but their dinner is not the main object of their lives. So all healthy minded people like making money ought to like it and enjoy the sensation of winning it; it is something better than money

A good soldier, for instance, mainly wishes to do his fighting well. He is glad of his pay-very properly so and justly grumbles when you keep him ten years without it-till, his main mission of life is to win battles, not to be paid for winning them. So of clergymen. The clergyman's object is essentially baptize and preach not to be paid for preaching. So of doctors. They like fees no doubt-ought to like them; yet if they are brave and well-educated the entire object to their lives is not fees. They on the whole, desire to cure the sick; and if they are good doctors and the choice were fairly to them, would rather cure their patient and lose their fee than kill him and get it. And so with all the other brave and rightly trained men: their work is first, their fee second-very important always; but still second.

The Main Points Of the given material are---

1. Money making is a common attraction in life.
2. But it cannot be the principal aim of well-educated, intellectual brave persons.

### **Précis Summary:**

Money-making is a common attraction in life. But it cannot be the principal aim of well educated, cultured and brave man. A brave soldier prizes honour and victory more than his pay. A good clergyman is more interested in the moral welfare of his people than his returns. A doctor (good) values the care of his patient far more than his fees. Thus with all the welleducated, intellectual persons, their work is first, money next.

### **Example 2**

English education and English language have done immense goods to India, inspite of their glaring drawbacks. The notions of democracy and self-government are the born of English education. Those who fought and died for mother India's freedom were nursed in the cradle of English thought and culture. The West has made contribution to the East. The history of Europe has fired the hearts of our leaders. Our struggle for freedom has been inspired by the struggles for freedom in England,

America and France. If our leaders were ignorant of English and if they had not studied this language, how could they have been inspired by these heroic struggles for freedom in other lands? English, therefore, did us great good in the past and if properly studied will do immense good in future.

English is spoken throughout the world. For international contact our commerce and trade, for the development of our practical ideas, for the scientific studies, English is indispensable "English is very rich in literature," our own literature has been made richer by this foreign language. It will really be a fatal day if we altogether forget Shakespeare, Milton, Keats and Shaw.

### Précis Summary

Notwithstanding its various defects English education has done great good to India. The ideas of democracy and self-government are its gifts. Nursed on English education the Indian leaders were inspired by the Western thought, culture and freedom struggles. They fought for and won their motherland's freedom. Being spoken throughout the world English is necessary for international contact, trade, commerce and science. English is rich in literature; its master mind cannot be neglected.

### Qualities of a good précis

A good précis shows the writing skills of a person. It must have the following qualities;

#### 1. Clarity

Clarity means getting your message across so that the receiver can understand what the writer is trying to convey. The writer can achieve clarity by using simple language and simple structure.

#### 2. Correctness

Mistakes in your writings always irritate the reader. We may consider the mistakes under the following headings:

- Misspelled words
- Mistakes in figures and dates

- Mistakes in punctuation
- Mistakes of grammar and structure

### 3. Objectivity

Objectivity means the ability to present or view facts uncolored by feelings, opinions and personal bias. A précis should be purely a summary of the original text without any addition (No personal opinion and no personal ideas)

### 4. Coherence

Coherence means the logical and clear interconnection of ideas in a written piece of work. The ideas should be well knitted so that the writer may not be confused and lose his interest.

### 5. Completeness

Another striking feature of a good précis is completeness. Completeness means that the writer should include all the important facts in a précis. To make it short he should not omit the important ideas

### 6. Conciseness

Conciseness means to say all that needs to be said and no more. The writer should write what is necessary and avoid writing unnecessary details. To achieve conciseness, notice the following suggestions:

- Omitting unnecessary details \* include only relevant material
- Eliminate wordy expressions \* Avoid unnecessary repetition

## Technical definition and description

A technical description is text that describes an object or process in terms of its function, organization, parts and details. ... A technical description can be used alone (e.g., a specification) or as part of a larger document (e.g., a proposal). Often technical documents contain several technical descriptions.

## Overview

Technical professionals are often required to define or describe a technical object, concept, or process to someone who has little knowledge or experience with it. For

example, an engineering firm might write a proposal to bid on a contract to develop a helicopter for the Defense Department; one section of the proposal would be a detailed description of the product the company proposes to develop. Technical descriptions are used before products and processes are developed (as part of proposals and planning documents), during development (in progress reports, for instance), and afterwards (as part of marketing and promotional literature and technical support documents).

### **What is a description and why is it used for in technical writing?**

Technical writers, , prepare instruction manuals, journal articles, and other supporting documents to communicate complex and technical information more easily. They also develop, gather, and disseminate technical information among customers, designers, and manufacturers.

### **Q. Write Technical Description of lathe machine**

#### **1.INTRODUCTION**

A lathe is a tool that rotates the work piece about an axis of rotation to perform various operations such as cutting, sanding, knurling, drilling, or deformation, facing, turning, with tools that are applied to the workpiece to create an object with symmetry about that axis.

A lathe machine is a machine tool which is used to remove metals from a work piece to give a desired shape and size. In other words it is a machine that is used to hold the workpiece to perform various metal removing operations such as turning, grooving, chamfering, knurling, facing, forming etc with the help of tools.

#### **2. Parts of Lathe Machine:**

- Bed. It is the main body of the machine. ...
- Tool post. It is bolted on the carriage. ...
- Chuck. Chuck is used to hold the workspace. ...
- Head stock. Head stock is the main body parts which are placed at left side of bed. ...
- Tail stock. Tail stock situated on bed. ...
- Lead screw. ...

- Legs. ... AND \*Carriage

## Diagram

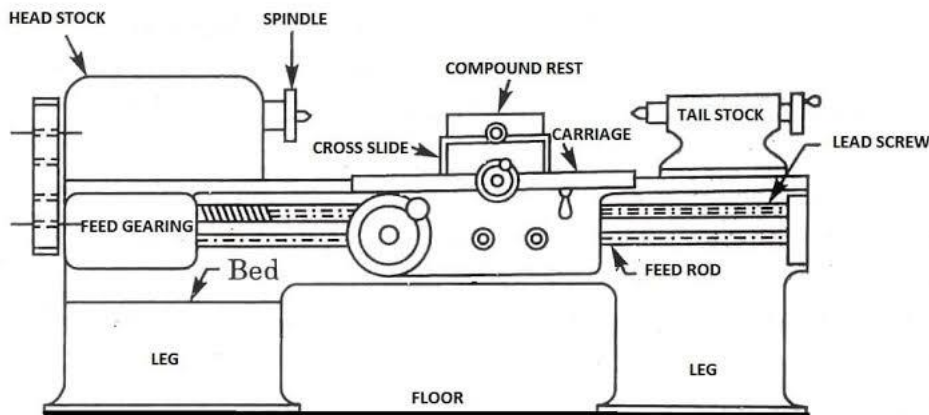

### 3. Working principle of lathe machine

**Working Principle:** The lathe is a machine tool which holds the workpiece between two rigid and strong supports called centers or in a chuck or face plate which revolves. The cutting tool is rigidly held and supported in a tool post which is fed against the revolving work

The normal cutting operations are performed with the cutting tool fed either parallel or at right angles to the axis of the work.

- 1. Bed:** The bed is a heavy, rugged casting in which are mounted the working parts of the lathe. It carries the headstock and tail stock for supporting the workpiece and provides a base for the movement of carriage assembly which carries the tool.
- 2. Legs:** The legs carry the entire load of machine and are firmly secured to floor by foundation bolts.
- 3. Headstock:** The headstock is clamped on the left hand side of the bed and it serves as housing for the driving pulleys, back gears, headstock spindle, live centre and the feed reverse gear. The headstock spindle is a hollow cylindrical shaft that provides a drive from the motor to work holding devices.
- 4. Gear Box:** The quick-change gear-box is placed below the headstock and contains a number of different sized gears.

**5. Carriage:** The carriage is located between the headstock and tailstock and serves the purpose of supporting, guiding and feeding the tool against the job during operation.

The main parts of carriage are:

- a). The saddle is an H-shaped casting mounted on the top of lathe ways. It provides support to cross-slide, compound rest and tool post.
- b). The cross slide is mounted on the top of saddle, and it provides a mounted or automatic cross movement for the cutting tool.
- c). The compound rest is fitted on the top of cross slide and is used to support the tool post and the cutting tool.
- d). The tool post is mounted on the compound rest, and it rigidly clamps the cutting tool or tool holder at the proper height relative to the work centre line.
- e). The apron is fastened to the saddle and it houses the gears, clutches and levers required to move the carriage or cross slide. The engagement of split nut lever and the automatic feed lever at the same time is prevented she carriage along the lathe bed.

**6. Tailstock:** The tailstock is a movable casting located opposite the headstock on the ways of the bed. The tailstock can slide along the bed to accommodate different lengths of workpiece between the centers. A tailstock clamp is provided to lock the tailstock at any desired position. The tailstock spindle has an internal taper to hold the dead centre and the tapered shank tools such as reamers and drills.

## Q. Write technical description of solar cooker

### 1. Introduction

A solar cooker is a device which uses the energy of direct sunlight to heat, cook. Many solar cookers currently in use are relatively inexpensive, low-tech devices, although some are as powerful or as expensive as traditional stoves and advanced, large-scale solar cookers can cook for hundreds of people. Because they use no fuel and cost nothing to operate, many nonprofit organizations are promoting their use worldwide in order to help reduce fuel costs (especially where monetary reciprocity is low) and air pollution, and to slow down the deforestation caused by gathering firewood for cooking. Solar cooking is a form of outdoor cooking and is often used in situations where minimal fuel consumption is important, or the danger of accidental fires is high, and the health and environmental consequences of alternatives are severe.

## 2. Working function

Solar cooking is done by means of the sun's UV rays.

A solar cooker lets the UV light rays in and then converts them to longer infrared light rays that cannot escape. Infrared radiation has the right energy to make the water, fat and protein molecules in food vibrate vigorously and heat up.

It is not the sun's heat that cooks the food, nor is it the outside ambient temperature, though this can somewhat affect the rate or time required to cook, but rather it is the sun's rays that are converted to heat energy that cook the food; and this heat energy is then retained by the pot and the food by the means of a covering or lid.

This occurs in much the same way that a greenhouse retains heat or a car with its windows rolled up. An effective solar cooker will use the energy of the sun to heat a cooking vessel and efficiently retain the energy (heat) for maximum cooking effectiveness.

**3.PARTS:-** 1) Solar box(peti) 2) Reflective glass 3) internal boxes

## 4. Diagram

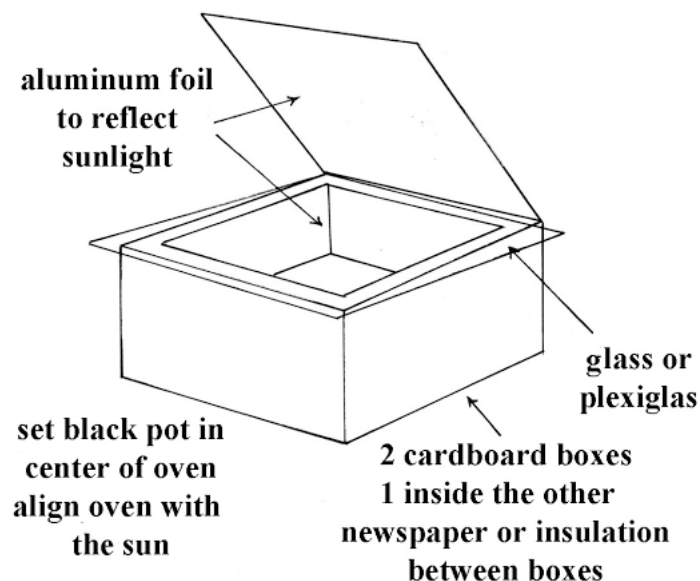

## 5. ADVANTAGES OF SOLAR COOKER

1. The biggest advantage of solar cookers is their eco-friendliness
2. Solar cooking is free once you have the cooker itself. To operate one, all you need is sunlight, so you can save a significant amount of money over the long term.
3. The quality of food cooked in a solar cooker is also notable

## DRAWBACK OF SOLAR COOKER

1. cooking with solar cookers obviously requires sunlight, which makes it difficult to use during winter months and on rainy days
2. Cooking also takes a significantly longer time compared to conventional methods

## REPORT WRITING

A report is a well planned document which outlines and evaluates a subject or problem .Report Writing is the primary tool of media personnel through which they pass on specific information about an incident or topic.

A report is written for a clear purpose and to a particular audience. Specific information and evidence are presented, analyzed and applied to a particular problem or issue. ... When you are asked to write a report you will usually be given a report brief which provides you with instructions and guidelines.

Apart from the media usage, report writing is required in various sectors like corporate, government, politics ,business ,public and private sector ,medical field, defense services.etc.

### What is the purpose of the report?

The Purpose of Reports. Reports communicate information which has been compiled as a result of research and analysis of data and of issues. Reports can cover a wide range of topics, but usually focus on transmitting information with a clear purpose, to a specific audience. ... The scope and style of reports varies wide

## TYPES OF REPORT WRITING

## 1. FORMAL REPORT

This type of report writing is usually preferred for an important incident, issue or matter by big organizations. Formal report writing is generally long and expensive.

Formal Report writing has an internationally accepted pattern that includes various components that are mentioned below.

**Cover** - The cover of a report is something that drives a reader's attention first. The report's cover leaves a huge impression on the reader's mind and he/she can get an idea regarding the report's topic or quality through the cover design.

There is a saying - "don't judge a book by its cover" but it is also true - what seems well, sells well and hence the report writer must take care of the cover of the report with has a major role to depict the report brief.

**Title Of The Report** - This component includes the report's title and the name of the writer. Apart from these things, the title can also have a date and the name of the organization for which the report has been prepared.

The cover also has these things but putting them in details in the title section is mandatory.

**Table Of Contents** - This section includes headings and subheadings of the primary text written. This is a very important portion of report writing. It helps your readers to reach desired sections in your report in a hassle-free manner.

**Summary** - Here you basically provide the synopsis of the whole report's primary text and you can also call it an informative summary.

Many times, it is referred as 'executive summary'. You can also use descriptive summary which is a simple table of contents. The format is always decided by the organization.

**Introduction** - This is the most important section of the main text. The main text always includes three components - introduction, discussion, and conclusion.

Here, you introduce the main text of your report in the most intriguing a detailed manner so that all types of readers can get your point without much effort.

Discussion - In the discussion section, a report writer discusses the main story of the report. According to your reader's convenience, you decide the order of the report's results.

You can also do a result to theory comparison here along with the analysis, evaluation and interpretation of the data included.

Conclusion/Recommendation - You can present the summary of the discussion section here. Here, you mention your findings and recommend the elements to your readers as per your overall evz

Appendices: This contains attachments relevant to the report. For example, surveys, questionnaires, etc.

Bibliography: This is the list of all references cited.

## **2. INFORMAL REPORTS**

This type of report writing is comparatively easier and less time-consuming than the formal report writing. Here, you need to perform lesser research and it also includes lesser components.

The basic components of informal report writing include - Introduction, Discussion & Reference/Recommendations. Different organizations include more components to this type as per their requirements.

## **THE IMPORTANCE OF REPORTS**

Unless you can communicate effectively, the knowledge and skills you acquire are of little use to others. You have to be able to collect information, organize it, and present it in a logical and concise form. Regardless of a report's target audience, the structure and organization must convey the exact meaning you intend. A well-written report can be helpful to your career while a poorly written report calls into question the credibility of your work and frustrates your reader.

## Structure of a formal report

### Structure of a formal report

Front Section	Title Page Letter of Transmittal Table of Contents
Main Section	Summary Introduction Discussion of Findings Conclusions and Recommendations
Back Section	References Appendix

## Essential Characteristics or Features of a Good Report

Report provides factual information depending on which decisions are made. So everyone should be taken to ensure that a report has all the essential qualities which turn it into a good report. A good report must have the following qualities:

### 1. Precision

In a good report, the report writer is very clear about the exact and definite purpose of writing the report. His investigation, analysis, recommendations and others are directed by this central purpose.

### 2. Accuracy of Facts

Information contained in a report must be based on accurate fact.

### 3. Relevancy

The facts presented in a report should not be only accurate but also be relevant.

### 4. Reader-Orientation

While drafting any report, it is necessary to keep in mind about the person who is going to read it. That's why a good report is always reader oriented. Readers

knowledge and level of understanding should be considered by the writer of report. Well reader-oriented information qualify a report to be a good one.

## 5. Simple Language

This is just another essential features of a good report. A good report is written in a simple language avoiding vague and unclear words

## 6. Conciseness

A good report should be concise but it does not mean that a report can never be long. Rather it means that a good report or a business report is one that transmits maximum information with minimum words.

## 7. Grammatical Accuracy

A good report is free from errors. Any faulty construction of a sentence may make its meaning different to the reader's mind. And sometimes it may become confusing or ambiguous.

## 8. Clarity

Clarity depends on proper arrangement of facts. A good report is absolutely clear. Reporter should make his purpose clear, define his sources, state his findings and finally make necessary recommendation.

## 9. Attractive Presentation

Presentation of a report is also a factor which should be consider for a good report. A good report provides a catchy and smart look and creates attention of the reader. Structure, content, language, typing and presentation style of a good report should be attractive to make a clear impression in the mind of its reader.

## 10. Unbiased Recommendation

Recommendation on report usually makes effect on the reader mind. So if recommendations are made at the end of a report, they must be impartial and objective. They should come as logical conclusion for investigation and analysis.

## TYPES OF REPORT

### 1. Laboratory report

IT IS A COMMON PRACTICE FOR ALL THE TECHNICAL STUDENTS TO WRITE THE LAB REPORTS SINCE THEIR SCHOOL DAYS. THIS IS THE ONLY REPORT WITH WHICH STUDENTS ARE VERY FAMILIAR AND COMFORTABLE

Lab reports are written to describe and analyze a laboratory experiment that explores a scientific concept. They are typically assigned to enable you to: Conduct scientific research. Formulate a hypothesis (es) about a particular stimulus, event, and/or behavior.

### 2. Project report

An assessment that takes place during a project or process, that conveys details such as what sub-goals have been accomplished, what resources have been expended, what problems have been encountered, and whether the project or process is expected to be completed on time and within budget. Progress reports are used by management to determine whether changes are necessary to an ongoing effort.

### 3. Survey report

The survey is a method for collecting information or data as reported by individuals. Surveys are questionnaires (or a series of questions) that are administered to research participants who answer the questions themselves.

A method of sociological investigation that uses question based or statistical surveys to collect information about how people think and act.

4. Observation report ---The Observation Report is used to provide a summary of the data collected in the Observation Schedule for one complete session. Refer to the Observation Report Notes for tips on completing the Observation Schedule

## Forms of report writing

### 1. Letter Form

2. Letter Text Form
3. Memorandum Form



If you have any queries please visit- <https://studywithakash.in/>

Gmail – [studywithakash311@gmail.com](mailto:studywithakash311@gmail.com)

+918871317984

**THANK YOU**